



TC-270 TRANSFER CASE SERVICE MANUAL

TABLE OF CONTENTS

	SECTION
<u>TC-270 TRANSFER CASE SERVICE MANUAL</u>	1.0
Introduction	1.1
Specification	1.2
Assembly Views.....	1.3
<u>LUBRICATION</u>	2.0
Recommended Lubricants	2.1
Off-Highway and Mining Equipment.....	2.2
Inspection	2.3
Oil Change.....	2.4
Draining the Oil.....	2.5
Refilling the Oil.....	2.6
Operating Temperature.....	2.7
<u>CLEANING & INSPECTION</u>	3.0
Cleaning.....	3.1
Drying & Corrosion Inhibition.....	3.2
Inspection.....	3.3
<u>GENERAL INSTRUCTIONS</u>	4.0
Safety.....	4.1
Assembly Precautions.....	4.2
Removal & Installation.....	4.3
<u>DISASSEMBLY</u>	5.0
General Disassembly.....	5.1
Disassembly of Subassemblies.....	5.2
Disassembly of the Upper Input Shaft.....	5.3
Disassembly of the Intermediate Shaft.....	5.4
Disassembly of the Rear Output Shaft.....	5.5
Disassembly of the Front Output Shaft and Carrier.....	5.6
<u>ASSEMBLY</u>	6.0
Assembly of Subassemblies.....	6.1
Assembly of the Upper Input Shaft.....	6.2
Assembly of the Intermediate Shaft.....	6.3
Assembly of the Rear Output Shaft.....	6.4
Assembly of the Front Output Shaft and Carrier.....	6.5
General Assembly.....	6.6
Assembly of the Oil Pump.....	6.7
<u>TORQUE SPECIFICATIONS</u>	7.0
<u>ILLUSTRATED PARTS AND LIST</u>	8.0
<u>TOOLS</u>	9.0

1.0 TC - 270 TRANSFER CASE

1.1 INTRODUCTION

The Fabco TC-270 two-speed transfer case is designed for use in all wheel drive vehicles. The transfer case provides drive to the front axle(s) and can be used in any configuration of rear driven axles. The front drive axle can be engaged at any vehicle speed, provided the rear wheels are not spinning; however, the vehicle must be stationary before the shift can be made between high and low ranges, otherwise serious damage may occur. The shifting between ranges and the engagement of front drive and power take-off clutches is accomplished by air-operated cylinders. A Lubrication pump is optional on all models and may be used for oil circulation should an oil cooler installation be deemed necessary.

1.2 SPECIFICATIONS

The TC-270 transfer case is a two-speed, three-shaft, constant-mesh design featuring a declutch for the front axle and underdrive engagement.

NOMINAL RATING

Input Torque	10,000 Lb. Ft.
Input Horsepower	350 HP
Input Speed	2,600 RPM

RATIOS

Direct	1:1
Underdrive	2.23:1

GEAR TYPE

Helical, Case Hardened

SHAFT SIZES

Input	2.50 Inches, 10 Parallel Spline
Front & Rear Output	2.75 Inches, 10 Parallel Spline

SHAFT SPACING (Drop)

16.25 Inches

SHIFT MECHANISM

Integral Air Cylinders

BEARINGS

Tapered Roller

LUBRICATION

Splash

LUBRICANT

See Section 2.0

OIL CAPACITY

11 Quarts (U.S.)

DRY WEIGHT

700 Lbs.

HOUSING

Cast Iron

OPTIONS

Full Power PTO, Air Shifted
Direct Mount SAE B & C Hydraulic Pump Drive
Lubrication Pump & Spin-on Filter (Standard with PTO)

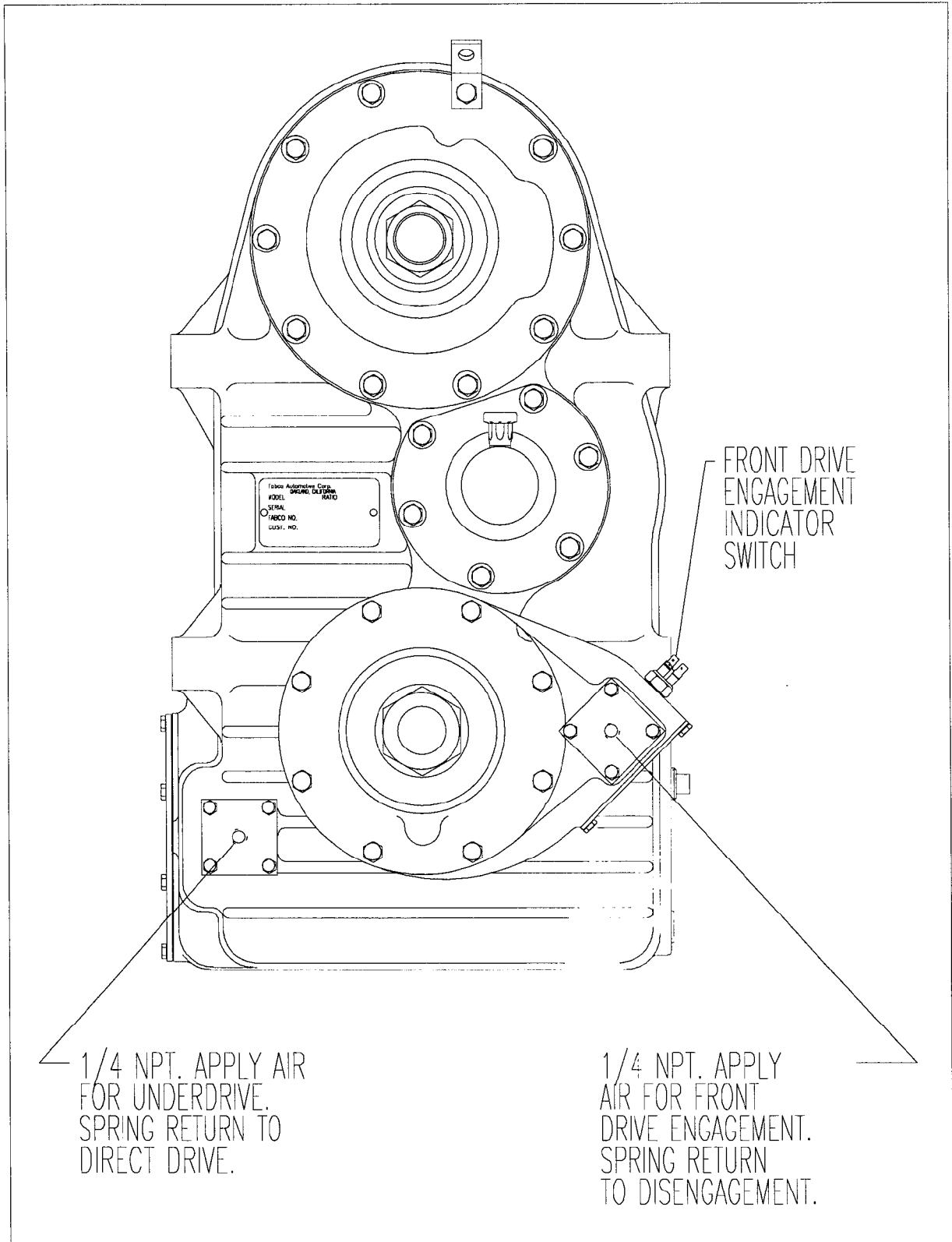

FRONT VIEW - FABCO TC-270 TRANSFER CASE

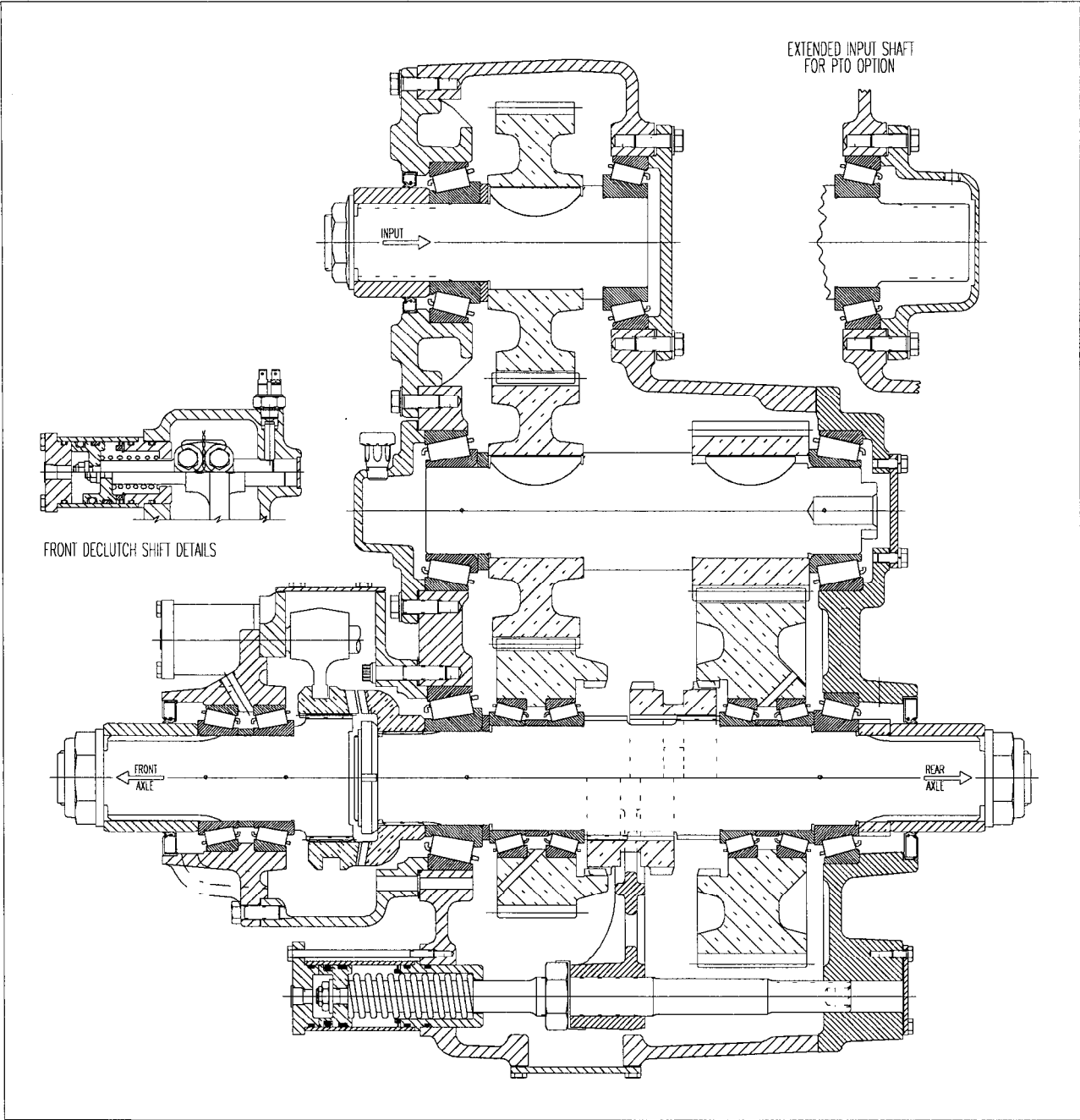

SECTIONAL VIEW - FABCO TC-270 TRANSFER CASE

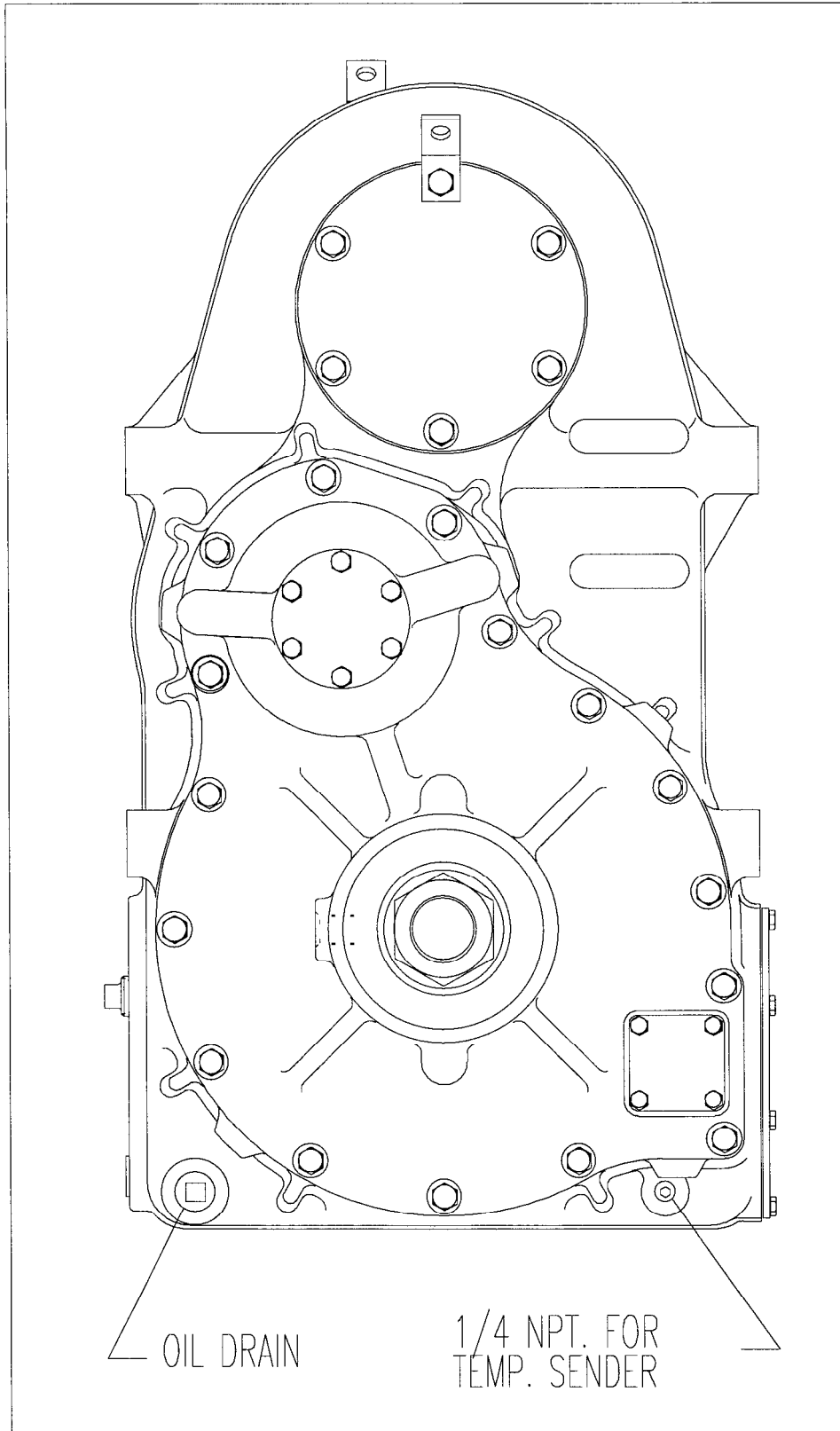

REAR VIEW - FABCO TC-270 TRANSFER CASE

2.0 LUBRICATION

2.1 RECOMMENDED LUBRICANTS

On-Highway Vehicles

1. Heavy Duty Engine Oil:

<u>Temperature</u>	<u>Grade</u>
Above + 10°F	SAE 50
Below + 10°F	SAE 30

Be sure to specify heavy-duty type meeting MIL-L-2104B specifications.

2. Mineral Gear Oil:

<u>Temperature</u>	<u>Grade</u>
Above + 10°F	SAE 90
Below + 10°F	SAE 80

Must be inhibited against corrosion, oxidation, and foam.

2.2 OFF-HIGHWAY & MINING EQUIPMENT

1. Heavy-Duty Engine Oil:

<u>Temperature</u>	<u>Grade</u>
Above + 10° F	SAE 50
Below + 10° F	SAE 30

Be sure to specify heavy-duty type, meeting MIL-L-2104B specifications.

2. Special Recommendation: For extreme cold weather where temperature is consistently below 0°F, use SAE 20W heavy-duty engine oil meeting MIL-L-2104B specifications.

NOTE: EXTREME PRESSURE (EP) OILS ARE NO LONGER RECOMMENDED FOR USE IN FABCO TRANSFER CASES. UNDER CERTAIN OPERATING CONDITIONS THESE OILS MIGHT FORM CARBON DEPOSITS ON GEARS, SHAFTS

2.3 INSPECTION

The oil is to be maintained at the level of the fill plug at all times. Check at the following intervals:

Highway Service..... 1,000 Miles

Off -Highway Service..... 40 Hours

With every oil change, the shift cylinder air lines and valves should be inspected for leaks and possible malfunctioning. Low pressure conditions can cause partial clutch engagement which may result in premature wear or damage.

2.4 OIL CHANGE

The transfer case lubricant should be changed on all new transfer cases after the first 3,000 to 5,000 miles (on-highway), or the first 40 hours (off-highway); thereafter oil changes should be done at the following intervals:

On-Highway Service..... 10,000-15,000 Miles

Off-Highway Service
(Logging, dirt moving,
mining, and associated
operations)..... 500-750 Hours

The recommended oil change and inspection periods are based on the average use and operating conditions that the unit may encounter. It is suggested that the individual owner make a periodic lab analysis of the lubricant to determine contamination based on the unit's specific operating conditions. With this data, the oil change and inspection periods can be better determined.

2.5 DRAINING THE OIL

Draining is best accomplished after the vehicle has been operated briefly, allowing the oil to become warm and flow more freely. Remove both drain and fill plugs. Allow the housing to empty completely. Before the unit is refilled, it should be thoroughly flushed with clean flushing oil or kerosene.

If the unit is equipped with an oil pump, the lube oil filter should be replaced whenever the oil is changed. The element is of the spin-on type. A film of clean oil should be applied to the rubber gasket of the new element before installing. Do not over tighten.

2.6 REFILLING THE OIL

If the transfer case has been removed from the vehicle for service, it is best to refill the oil after the unit has been reinstalled into the vehicle.

Clean and replace the drain plug and fill the transfer case with the appropriate oil with the vehicle on level ground. Fill the transfer case to the level of the fill plug. The plug should be installed only after the oil level has stabilized.

For each transfer case the oil capacity will vary somewhat, depending on the model and the inclination of the unit; therefore, always fill to the level of the fill plug. Do not overfill. Inspect for leaks.

2.7 OPERATING TEMPERATURE

The operating temperature of the transfer case should not exceed 250°F (120°C). Extensive operation at temperature exceeding 250°F will result in rapid breakdown of the oil and may shorten the transfer case life. If reduction of operating speed is not acceptable then the case may have to be equipped with an external oil cooler to maintain the operating temperature below 250°F.

The following conditions may contribute to excessive oil temperature.

1. A vehicle remaining stationary for extended periods while operating the power take-off.
2. A vehicle which is used in tropical or desert conditions.
3. A vehicle where extended body work or an accumulation of dirt and plant material may shield the case from air ventilation and circulation.
4. A vehicle that is operated for extended distances at high speed with the main transmission in overdrive.

3.0 CLEANING AND INSPECTION

3.1 CLEANING

Steam may be used for external cleaning of completely assembled units. Care must be taken to ensure that water is kept out of the assembly by sealing breather caps and other openings.

The transfer case housing which, is too large to conveniently clean with solvents, may be immersed in a hot solution tank containing a mild alkaline solution. Aluminum parts such as the carriers, caps, declutch housings, and air shift cylinder components must never be cleaned in any type of alkaline solution. Parts cleaned in a hot solution tank must be rinsed thoroughly to prevent damage by traces of alkaline material.

Parts with ground or polished surfaces, such as bearings, gears, shafts, and oil pump components should be cleaned with emulsion cleaners or petroleum solvents. An alkaline solution may damage the machined surfaces and such cleaning methods should be avoided.

3.2 DRYING AND CORROSION INHIBITION

Dry compressed air or clean, soft shop towels should be used to dry parts after cleaning. Bearings should never be spun dry with compressed air.

Dried parts should be immediately coated with a light oil or corrosion inhibitor to prevent corrosion damage. Parts which are to be stored should also be wrapped in heavy waxed paper or plastic bags and kept dust-free.

3.3 INSPECTION

Prior to reassembly, parts which are to be reused must be carefully inspected for signs of wear or damage. Replacement of such parts can prevent costly downtime at a future date.

All bearing surfaces, including roller bearing cups and cones, should be examined for pitting, wear, or overheating. Gears may also show pits, as well as scoring and broken teeth. Shafts may be nicked or marred, or have damaged threads. Parts which show any sign of damage should be repaired or replaced.

Inspect the rotor, housing, and idler of the oil pump (if equipped) for scoring. Inspect the

drive tab of the rotor assembly. If any damage is noted, the pump cartridge assembly should be replaced as a unit.

Check all shift forks and slots in sliding clutches for wear or discoloration due to heat. Check the engaging teeth for a partial engagement wear pattern.

4.0 GENERAL INSTRUCTIONS

4.1 SAFETY

The servicing and maintenance of components from any automotive vehicle present possible hazards, every endeavor should be made to minimize the risks taken to successfully complete the task. For your protection we offer these warnings and suggestions.

1. When working on, around, or under the vehicle the parking brake should be securely applied and all wheels should be blocked to prevent wheel movement. Do not rely on the vehicle being in gear with a dead engine to prevent movement. All work should be performed on a flat level surface free of loose material.
2. When working under a vehicle, it should be raised and supported with the appropriate frame stands or very secure blocking.

 **WARNING:** NEVER WORK UNDER A VEHICLE WHILE SUPPORTED ONLY ON A FLOOR JACK OR HOIST.

3. Be sure any lifting equipment has adequate capacity to raise the vehicle or component being lifted. This includes hydraulic floor jacks, crane type hoists, transmission jacks, and axle support dollies, etc. The weight of Fabco components is given in the front of the applicable service manual.
4. Caution must be exercised when cleaning the component or underside of the vehicle. Compressed air should not be used to blow dirt away as any harmful contaminant material on the bottom of the vehicle will be spread around the work area.

Appropriate solvents and cleaning solutions can be used in accordance with their labeling instructions or by referring to the Material Safety Data sheet (MSDS) that is available for each cleaner. Approved protective eyewear, gloves, masks and clothing should always be worn.

5. Fabco has not used Asbestos in any of its products manufactured since May of 1989 and was used only in axle brake linings prior to that time. See the separate Asbestos Warning if you suspect asbestos may be present on the vehicle or component in the area to be serviced.

4.2 ASSEMBLY PRECAUTIONS

1. Read the instructions completely before starting reassemble. Refer to the appropriate exploded view in the parts manual.
2. All parts must be clean. The gasket surfaces must be free of old gasket material. Do not reuse old gaskets.
3. Bearing cup bores, shaft splines and bearing mounting surfaces, should be coated with Lubriplate or equivalent. This is necessary to reduce the possibility of galling.
4. All used oil seals must be replaced and the new oil seals should be coated with Loctite 601 or equivalent on their outer diameter prior to being installed in their bores. The sealing lips should be coated with Lubriplate or the equivalent to provide initial lubrication.
5. Any external cap screw, not installed in a blind hole, should have its threads coated with Permatex Form-A-Gasket #2 or an equivalent non-hardening sealer to prevent an oil leak.
6. All threaded fasteners should be tightened to the torque specified in the torque chart.
7. Any sharp edges on the seal diameter of the universal joint yoke or companion flanges should be removed with emery cloth and should also be coated with Lubriplate or the equivalent on the seal operating area prior to installation.
8. In many of the procedures, when a part is assembled with a press fit, it is recommended that the part be heated prior to installation. The part should be placed in an oven and heated to no more than 300°F. Excessive heat may change the metallurgical properties of the part. Heated components should be allowed to cool to room temperature before end float measurements are made.

 **CAUTION:** ALTHOUGH FABCO DOES NOT RECOMMEND ITS USE IN TRANSFER CASES, IF FORMED-IN-PLACE GASKET IS USED FOR REPAIRS, EXTREME CAUTION MUST BE EXERCISED TO PREVENT THE COMPOUND FROM ENTERING BEARINGS, OIL GALLERIES, PASSAGES OR TAPPED HOLES. ALL BEADS MUST BE KEPT SMALLER THAN 1/8 INCH DIAMETER.

4.3 REMOVAL & INSTALLATION

4.3.1 REMOVAL

1. Remove fill and lower drain plugs and drain gear lubricant.
2. Disconnect wires leading to indicator light switch, and temperature sensor, if used.
3. Disconnect and tag shift cylinder air lines.
4. Disconnect speedometer cable.
5. Disconnect drivelines at flanges or yokes.
6. If the transfer case is equipped with a PTO mounted hydraulic pump, remove four capscrews and slide pump out of PTO. Secure the pump to the frame to avoid damage to hydraulic lines. The pump should be secured in a position that will not hinder the removal of the transfer case.
7. Position a transmission jack of suitable capacity beneath the transfer case. The transfer case must be seated on the jack in a safe and firm position.
8. Disconnect transfer case mountings at the rubber shock insulators. Since mounting designs vary, consult the vehicle service manual.
9. After making sure that all mountings and connections to the transfer case are disconnected lower the transfer case gradually to the floor. It is imperative that the transfer case is **ALWAYS** safely positioned on the transmission jack to safeguard the transfer case from falling off the jack. Remove the transfer case from beneath the vehicle. It may be necessary to jack the truck up to allow room to remove transfer case.
3. Raise the transmission jack to properly locate the transfer case.
4. Connect transfer case mountings. Since mounting designs vary, consult vehicle service manual.
5. Connect the drivelines.
6. Connect the speedometer cable.
7. Connect the shift cylinder air lines.
8. Connect the indicator light and temperature sensor wires.
9. Fill the housing with the appropriate lubricant to the correct level and install the level plug.
10. Check the transfer case for leaks around the gaskets and seals.

NOTES

4.3.2 INSTALLATION INTO THE VEHICLE

1. Place the transfer case onto the transmission jack, preferably lifting by means of the eye bolts.
2. Position the transmission jack underneath the vehicle. Some vehicles may require that one side be jacked up in order to achieve sufficient clearance to place the transfer case between the frame rails.

ASBESTOS WARNING

SUGGESTED PROCEDURES FOR WORKING WITH COMPONENTS SUSPECTED OF CONTAINING ASBESTOS

Asbestos has been found to be a primary cause of various forms of respiratory disease and cancer of several vital body organs. Primary ingestion is by breathing or swallowing dust containing fibers and can place smokers at a greater risk than those who do not smoke. The onset of disease can be at an extended period of time, (several years) after the exposure. The Occupational and Safety Health Administration (OSHA) has established very stringent limitations for exposure to asbestos fibers by workers using the material, and every precaution should be taken to minimize the risks involved. The following are some suggested procedures to adopt when working with material that has, or may be suspected of containing, asbestos.

1. Approved protective clothing, gloves, eye shield and aprons should be worn whenever working around the suspected material. NIOSH & OSHA approved respirator masks suitable for asbestos dust should be worn at all times. Disposable dust face masks are not allowed by OSHA.
2. Do not smoke while working on any asbestos related material or wearing protective apparel.
3. Do not eat or drink food while wearing protective clothing. Always wash before eating or drinking.
4. Do not use compressed air for any dirt removal. Use only approved high efficiency vacuum cleaners suitable for use with asbestos. Do not dry brush deposits or accumulations of dirt from components. What cannot be removed with the high efficiency vacuum cleaner should be washed with a water soaked rag. The rag should not be wrung dry but should be disposed of, together with other wastes containing asbestos in specially sealed and marked containers in accordance with EPA and OSHA regulations.
5. Do not wear protective clothing away from the working area, vacuum clean clothing before removal. Shower, if possible, before going home.

These suggestions are neither complete nor authoritative on the subject of working with asbestos but are meant as a warning of possible risk. It is the responsibility of the supervising authority to be aware of the possible dangers involved and to provide suitable training, precaution and protection for those working in an asbestos environment.

5.0 DISASSEMBLY

Disassembly and assembly of the Fabco TC-270 transfer case is a relatively simple procedure which can be made easier by the use of some very simple tooling. Details of all tooling are given in the tooling section for manufacture in your own facilities or Fabco Automotive may be contacted for a price and availability.

5.1 GENERAL DISASSEMBLY

1. After removing the transfer case from the vehicle, thoroughly clean the exterior.
2. Remove the drain plug and drain the oil.

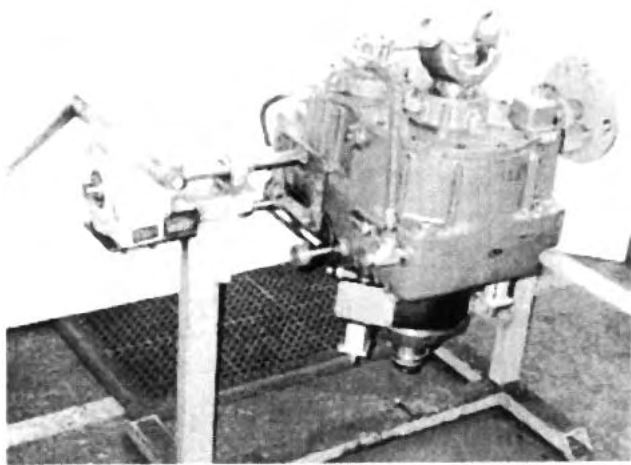

Fig. 1

3. Mount the transfer case in a suitable fixture. The fixture should be such that the transfer case can be rotated so that either the front or the rear of the case is facing upward. A transfer case mounted in a typical fixture is shown in Fig. 1.

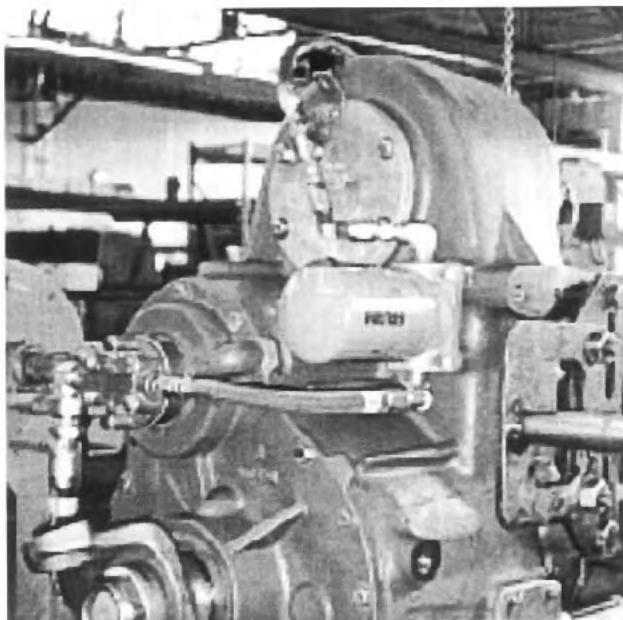

Fig. 2

4. If so equipped, remove the lubrication lines and filter. **Note the location and routing of the lines so that they may be correctly reinstalled.** See Fig. 2.

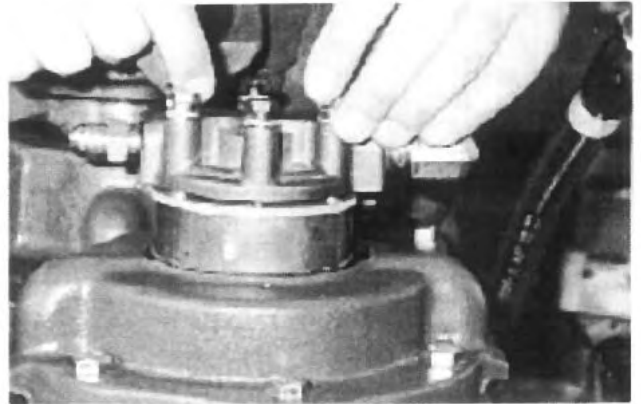

Fig. 3

5. If so equipped, remove the oil pump cap, shims, spacer ring, oil pump cartridge assembly and pressure relief spring. On all other models, remove the blanking cover. See Fig. 3.

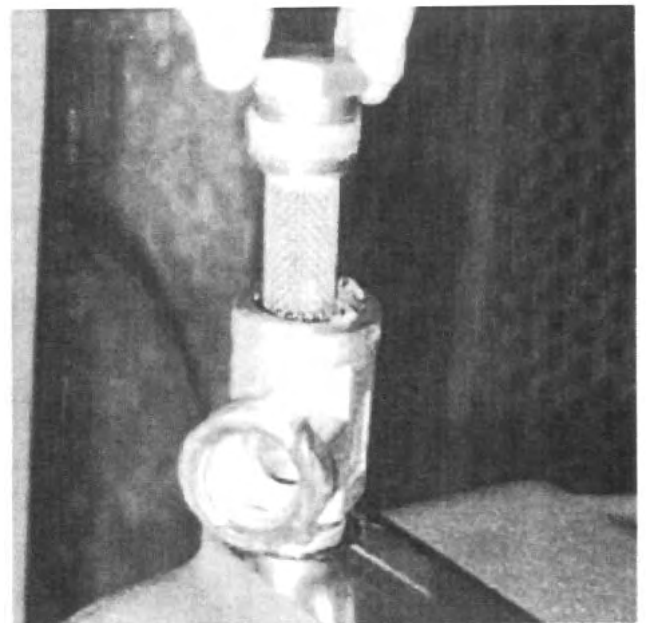

Fig. 4

6. If so equipped, remove oil strainer. See Fig. 4.

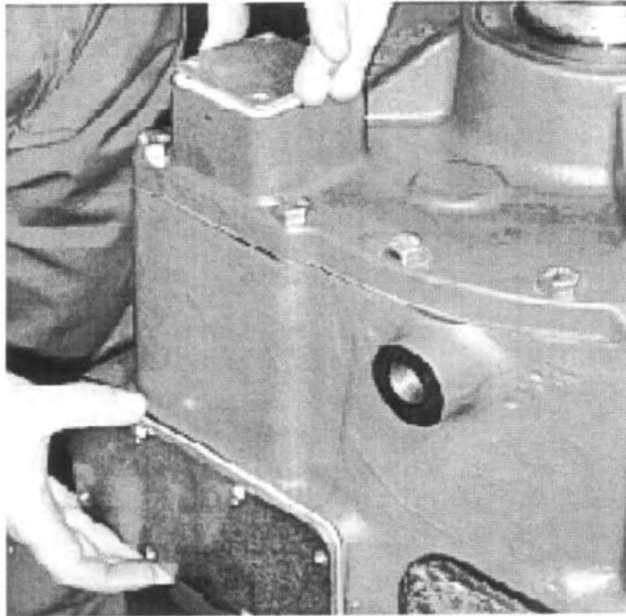

Fig. 5

7. Remove the shift shaft access cover plate and shift cylinder bore cap. See Fig. 5.



Fig. 6

8. Remove the rear output yoke. See Fig. 6.

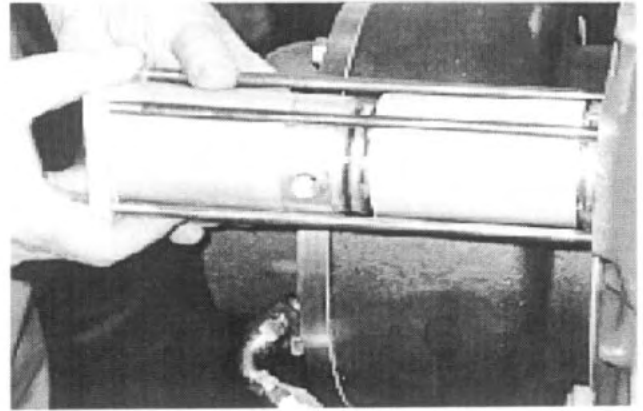

Fig. 7

9. Remove the air shift cylinder (and neutral, which is shown, if so equipped), located on the front side of the transfer case. See Fig. 7.

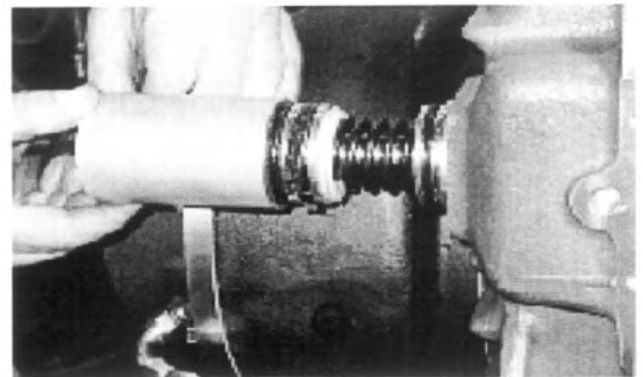

Fig. 8

10. Gently rock the cylinder to and fro to aid in removing the bottom portion of the air shift cylinder. See Fig. 8.

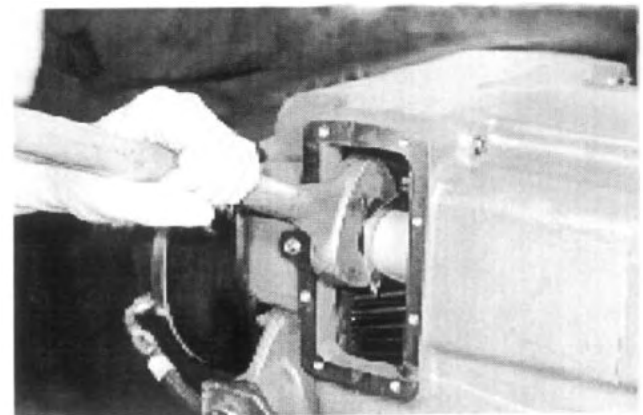

Fig. 9

11. Bend straight the tabs of the lock plate on the shifter shaft assembly inside the transfer case. Using a 9/16" Allen wrench inserted into the shift cylinder bore, and an open end wrench, loosen the adjustment nut on the shifter shaft assembly. See Fig. 9.

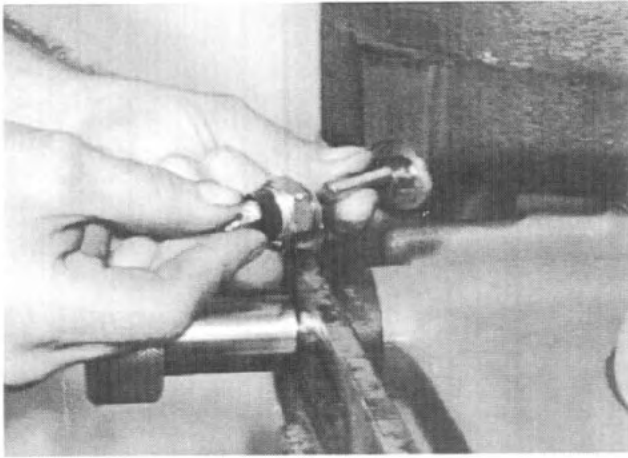

Fig. 10

12. Remove the front drive engagement indicator switch sender unit and copper washer. Using a pencil magnet, remove sensor pin from the indicator switch sender hole. *See Fig. 10.*

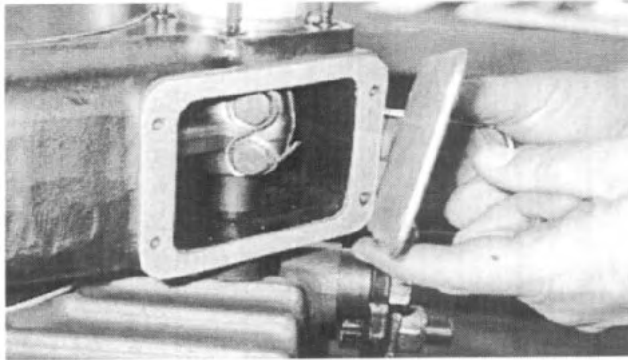

Fig. 11

13. Remove access plate to the front declutch housing shift fork assembly. *See Fig. 11.*

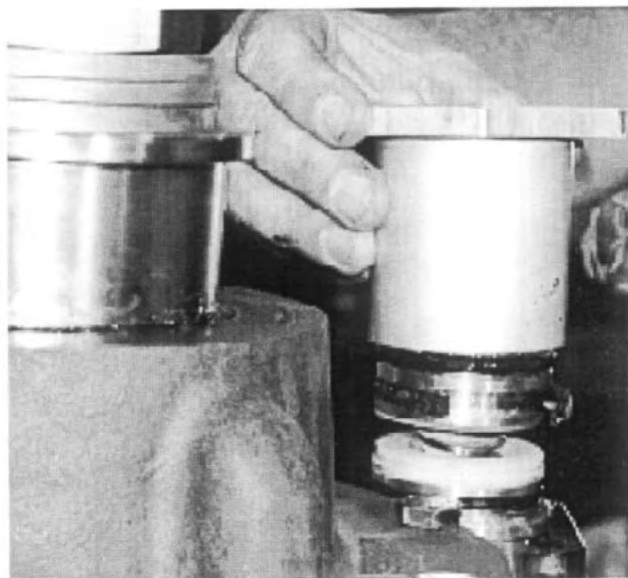

Fig. 12

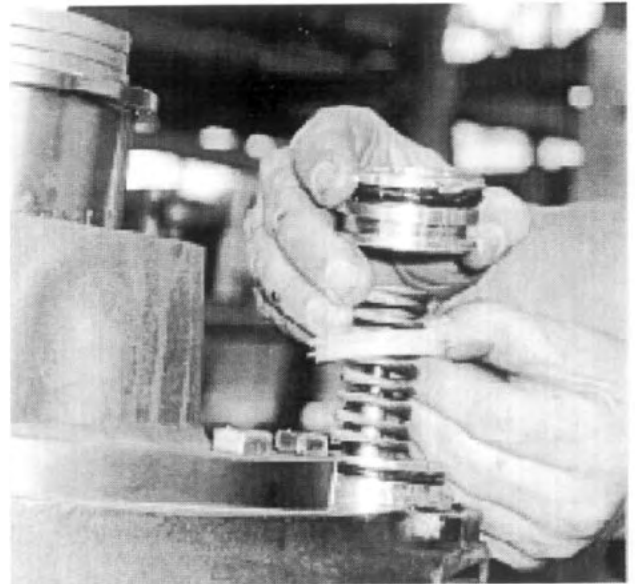

Fig. 13

14. Remove the front declutch air cylinder, disassembling piston, spring and stops. *See Figs. 12 & 13.*

⚠ CAUTION: SPRING ASSEMBLY IS PRELOADED. OBSERVE SAFETY PRECAUTIONS WHEN DISASSEMBLING.

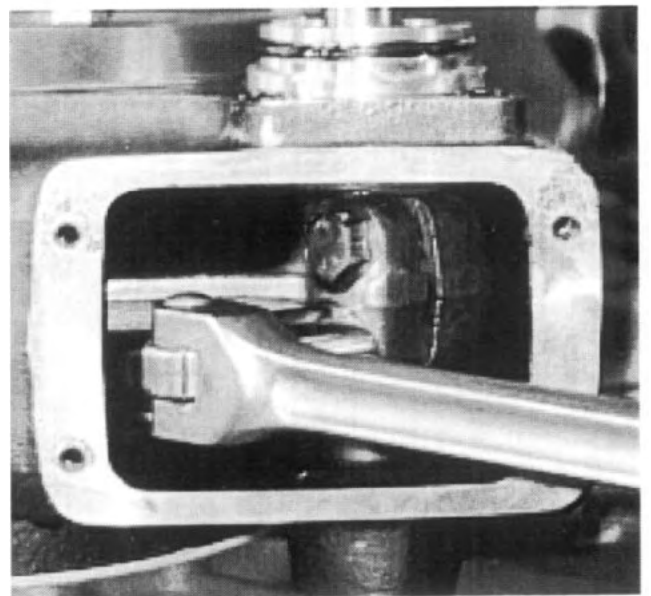

Fig. 14

15. Remove and discard the lock wire on the shift fork assembly. Loosen, but do not remove the two (2) bolts. *See Fig. 14.*

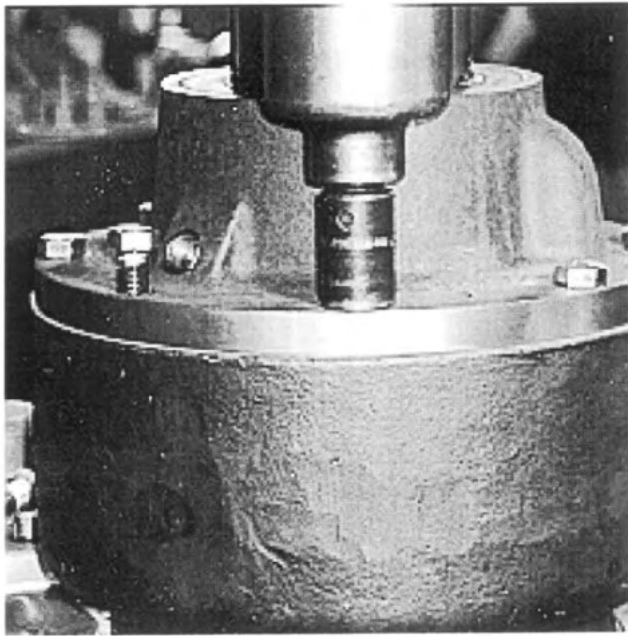

Fig. 15

16. Remove the eight (8) bolts attaching the front output shaft carrier to the front declutch housing, remove the front output shaft assembly and gasket from the transfer case. *See Fig. 15.*

NOTE: IT IS NOT NECESSARY TO DISASSEMBLE FURTHER THE SHAFT ASSEMBLY, UNLESS ONE OR MORE COMPONENTS ARE TO BE REPLACED. SEE SECTION 5.6 FOR FRONT OUTPUT SHAFT DISASSEMBLY.

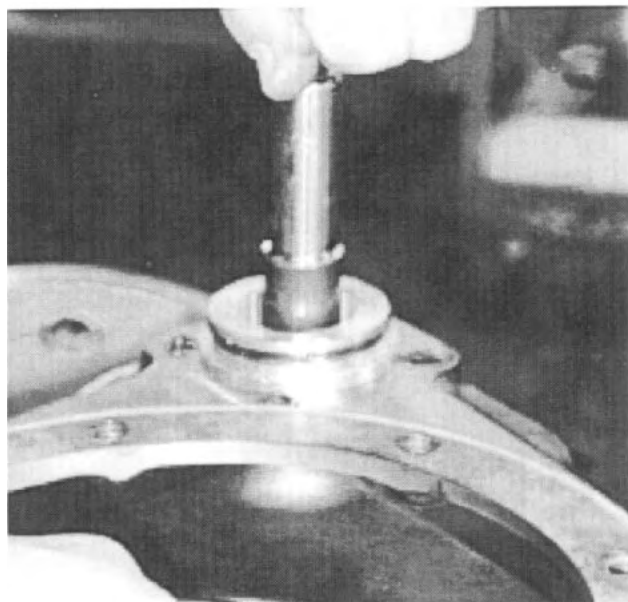

Fig. 16

17. Remove the two (2) bolts from the shift fork assembly. Remove the shifter shaft from the front declutch housing. *See Fig. 16.*

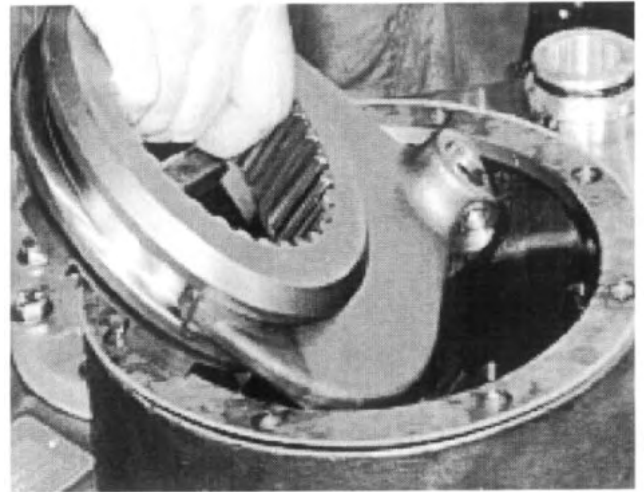

Fig. 17

18. Remove the fork and gear assembly from the front declutch housing. *See Fig. 17.*

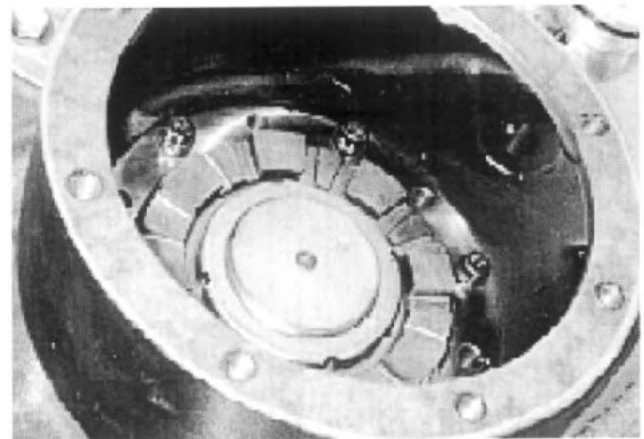

Fig. 18

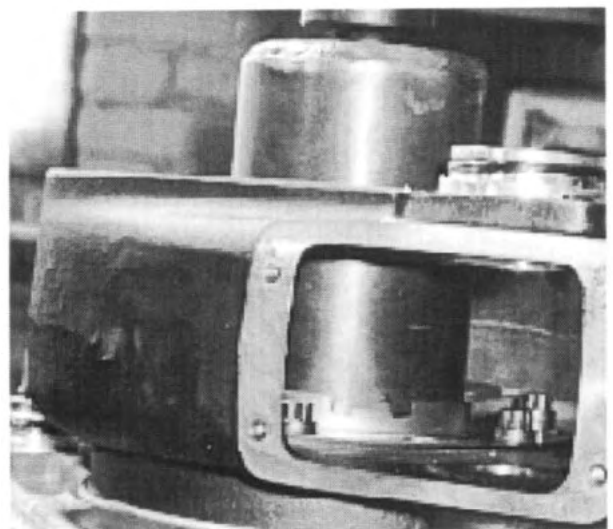

Fig. 19

19. Using special tool # 866 687 006, remove the bearing lock nut from the front of the lower shaft. *See Figs. 18 & 19.*

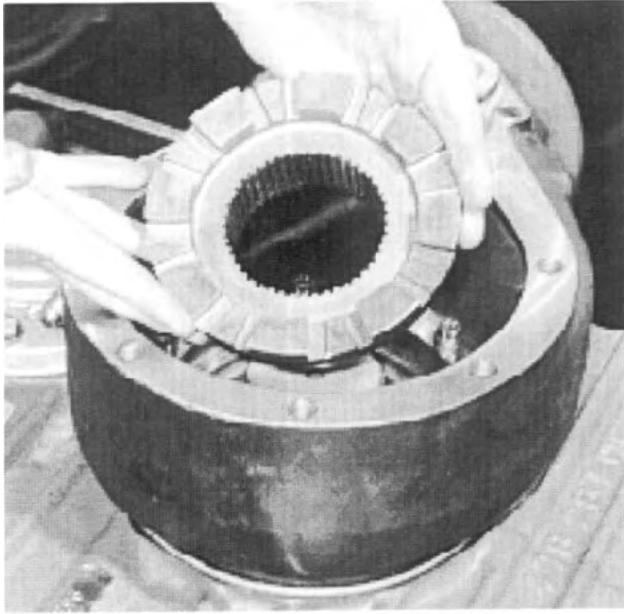

Fig. 20

20. Remove the declutch gear from the front declutch housing. See Fig. 20.

NOTE: LEAVE THE FRONT DECLUTCH HOUSING ATTACHED TO THE TRANSFER CASE.

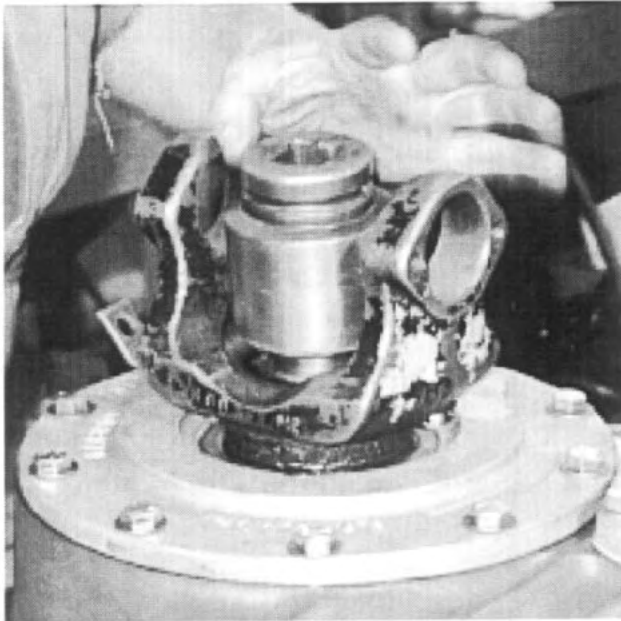

Fig. 21

21. Remove the yoke from the upper input shaft. See Fig. 21.

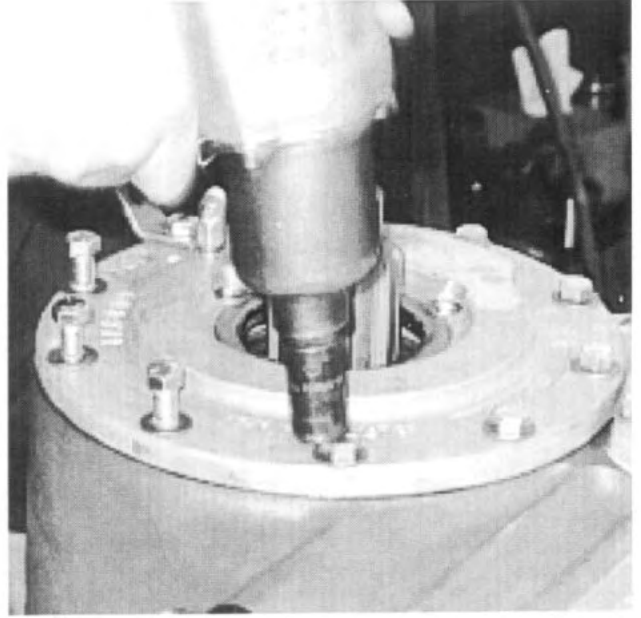

Fig. 22

22. Remove the ten (10) bolts securing the seal and bearing carrier of the upper input shaft. See Fig. 22.

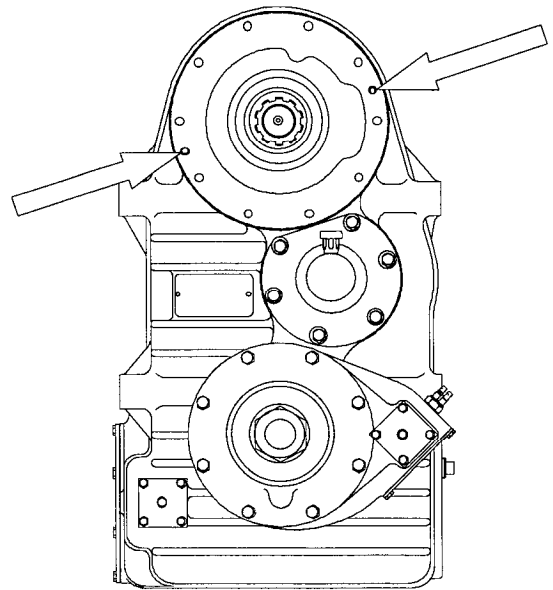

Fig. 23

23. Screw two (2) 7/16-14 NC bolts into the carrier to aid in lifting it from the transfer case housing. See Fig. 23.

CAUTION: DO NOT USE SCREW DRIVERS OR PRYBARS TO LIFT THE COVER AWAY FROM THE TRANSFER CASE HOUSING. THIS COULD SERIOUSLY DAMAGE THE MACHINED SEALING SURFACES AND RESULT IN THE TRANSFER CASE LEAKING WHEN REASSEMBLED.

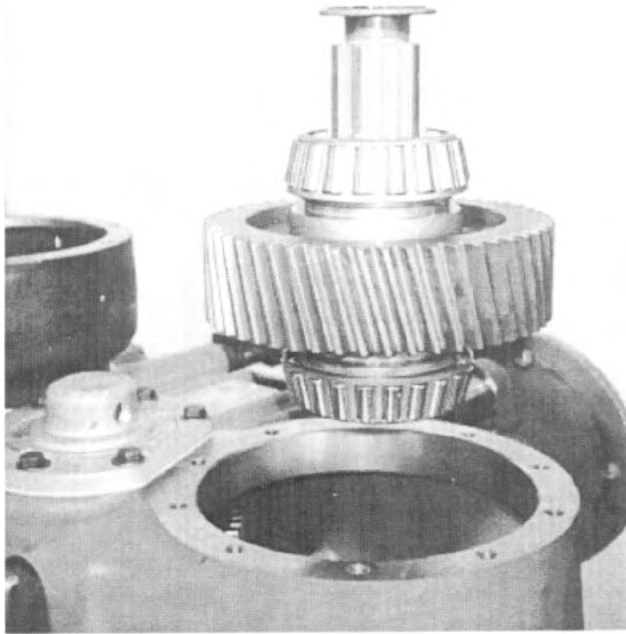

Fig. 24

24. Remove the upper input shaft assembly from the transfer case housing. To prevent damage, store the upper input shaft in a secure area. See Fig. 24.

NOTE: IT IS NOT NECESSARY TO DISASSEMBLE FURTHER THE SHAFT ASSEMBLY, UNLESS ONE OR MORE COMPONENTS ARE TO BE REPLACED. SEE SECTION 5.3 FOR UPPER INPUT SHAFT DISASSEMBLY.

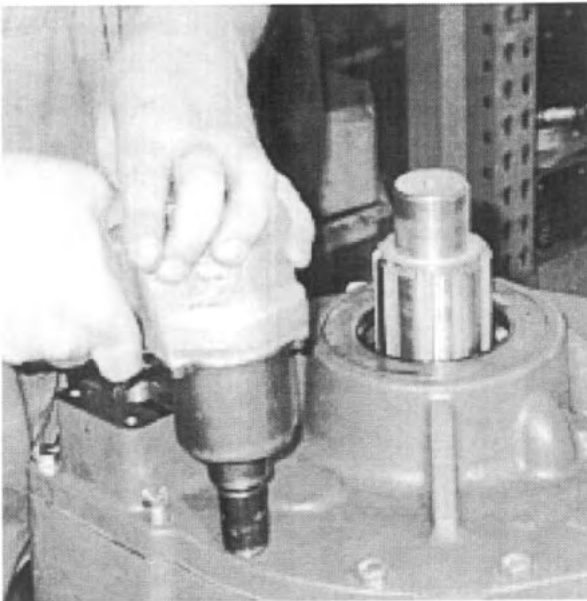

Fig. 25

25. Remove the fifteen (15) bolts holding the rear carrier to the transfer case housing. See Fig. 25.

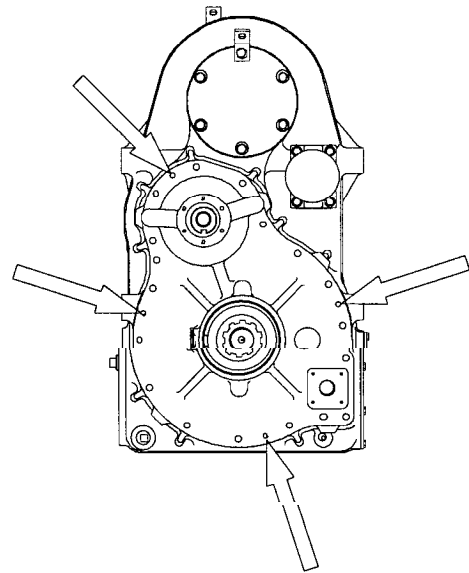

Fig. 26

26. Install four (4) 7/16-14 NC bolts into the rear carrier and tighten equally to force the carrier from the transfer case housing. See Fig. 26.

CAUTION: DO NOT USE SCREWDRIVERS OR PRYBARS TO LIFT THE COVER AWAY FROM THE TRANSFER CASE HOUSING. THIS COULD SERIOUSLY DAMAGE THE MACHINED SEALING SURFACES AND RESULT IN THE TRANSFER CASE LEAKING WHEN REASSEMBLED.

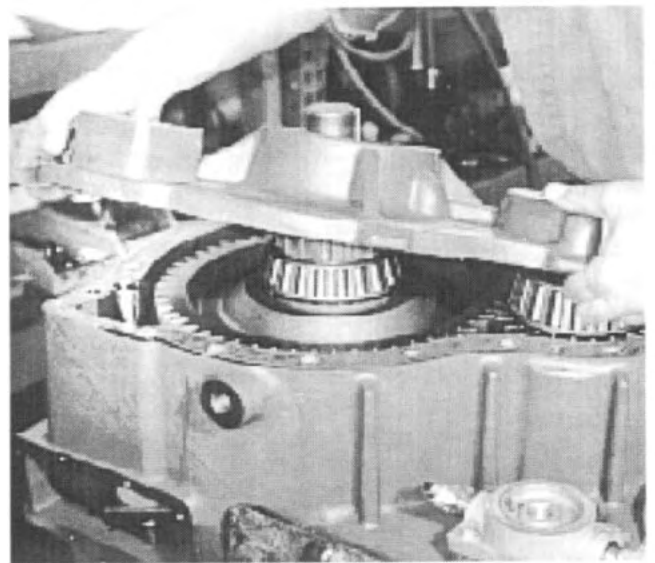

Fig. 27

27. Remove the rear carrier. Remove the oil seal from the rear carrier and discard. Remove the bearing cups from the carrier only if necessary. See Fig. 27

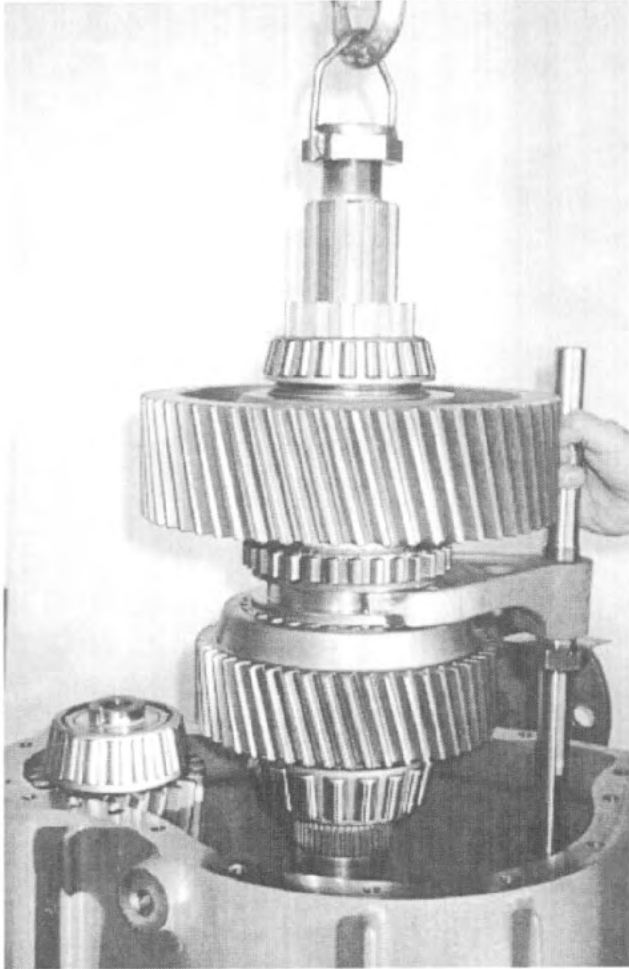

Fig. 28

26. Remove the rear lower output shaft and shifter shaft assembly from the transfer case housing. To prevent damage to the shaft assembly, store the assembly in a secure area. See Fig. 28.

NOTE: IT IS NOT NECESSARY TO DISASSEMBLE FURTHER THE SHAFT ASSEMBLY, UNLESS ONE OR MORE COMPONENTS ARE TO BE REPLACED. SEE SECTION 5.5 FOR REAR LOWER OUTPUT SHAFT DISASSEMBLY.



Fig. 29

27. Remove the intermediate shaft assembly from the transfer case housing. To prevent damage to the shaft assembly, store the assembly in a secure area. See Fig. 29.

NOTE: IT IS NOT NECESSARY TO DISASSEMBLE FURTHER THE SHAFT ASSEMBLY, UNLESS ONE OR MORE COMPONENTS ARE TO BE REPLACED. SEE SECTION 5.4 FOR INTERMEDIATE SHAFT DISASSEMBLY.

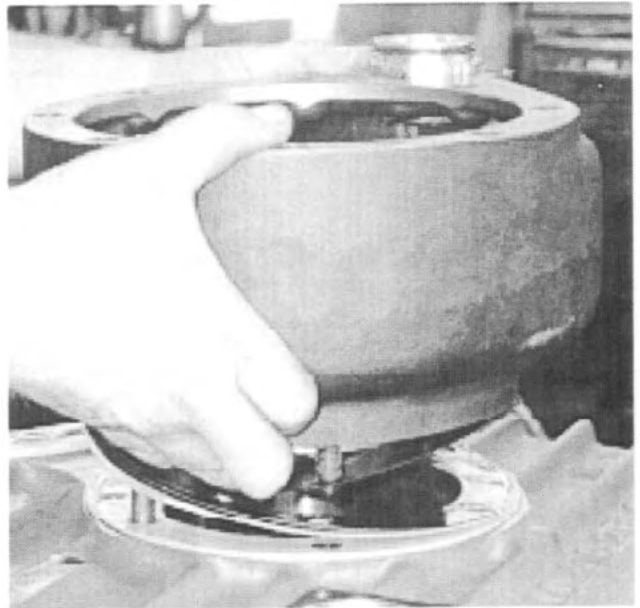

Fig. 30

27. Remove the front declutch housing, and, if required, any other gaskets, shims, caps, carriers or bearing cups. See Fig. 30.

THIS CONCLUDES THE GENERAL DISASSEMBLY OF THE TRANSFER CASE

5.2 DISASSEMBLY OF SUBASSEMBLIES

During a normal overhaul, it is neither necessary nor desirable to completely disassemble the shaft assemblies. The bearing cone assemblies and the drive train gears are installed with a press fit to the shaft and their unnecessary removal only increases the likelihood of damage. This caution also applies to the bearing cups installed in the carriers.

5.3 DISASSEMBLY OF THE UPPER INPUT SHAFT

1. Remove the oil seal from the carrier and discard. Remove the bearing cup from the carrier only if it is to be replaced.

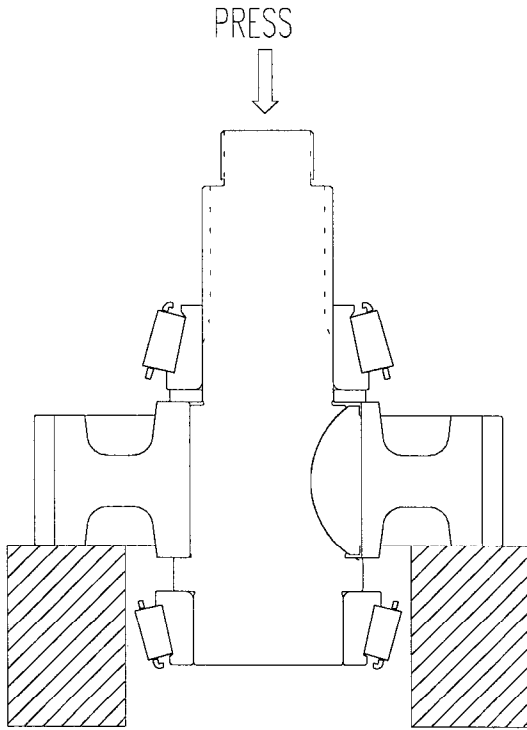

Fig. 31

2. Place the shaft assembly in a press such that the rear of the gear is supported and the press arbor bears against the threaded end of the shaft. Remove the front bearing cone, spacer and gear. Remove the shaft key only if necessary. See Fig. 31.

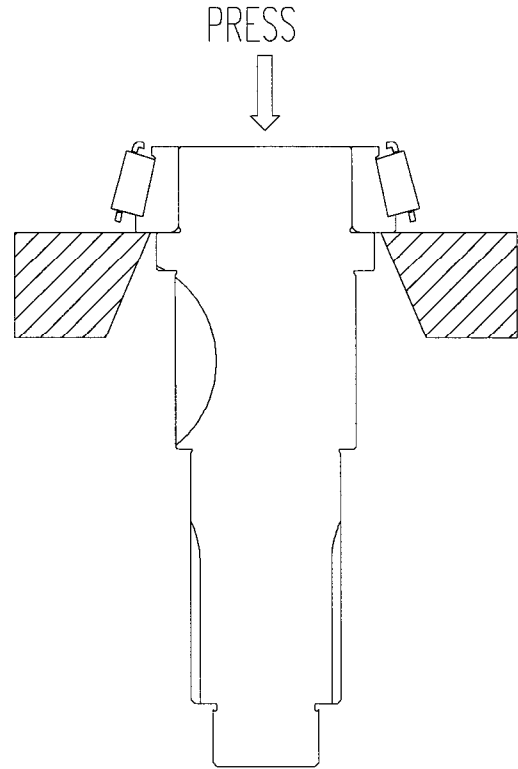

Fig. 32

3. To remove the rear bearing cone, support the bearing cone with a separator and press the shaft through the cone. See Fig. 32.

THIS CONCLUDES THE DISASSEMBLY OF THE UPPER INPUT SHAFT

5.4 DISASSEMBLY OF THE INTERMEDIATE SHAFT

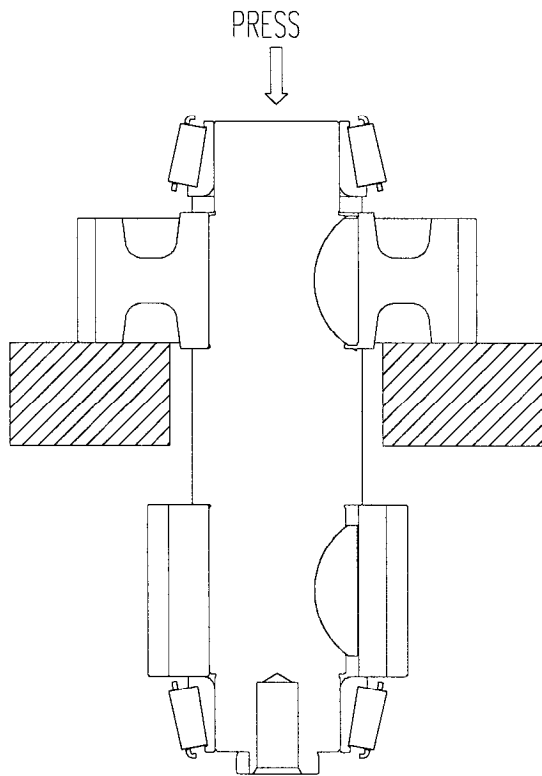

Fig. 33

1. To remove the rear bearing cone, spacer and the intermediate direct drive gear, support the direct drive gear. Press the shaft through the bearing, spacer and gear. Remove the shaft key only if necessary. See Fig. 33.

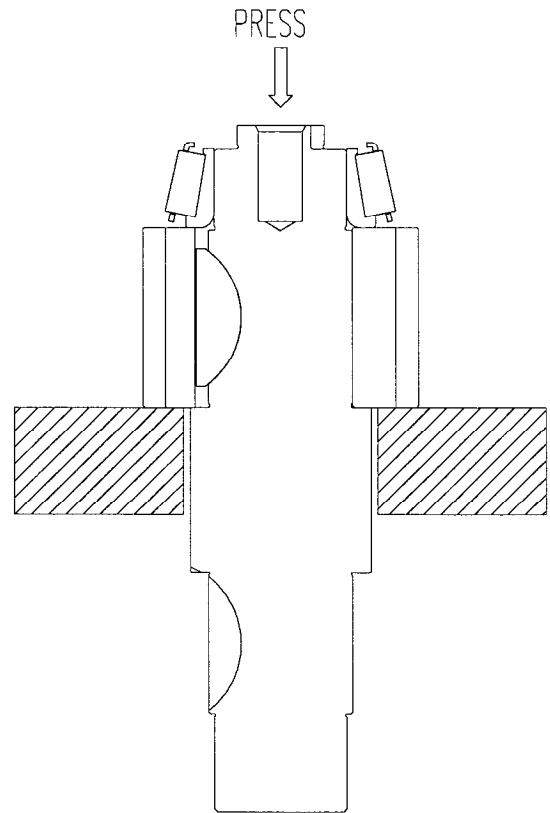

Fig. 34

2. Place the intermediate shaft assembly in a press such that the underdrive gear is supported and the press arbor bears against the end of the shaft. Remove the front bearing cone and the underdrive gear. Remove the shaft key only if necessary. See Fig. 34.

THIS CONCLUDES THE DISASSEMBLY OF THE INTERMEDIATE SHAFT ASSEMBLY

5.5 DISASSEMBLY OF THE REAR OUTPUT SHAFT

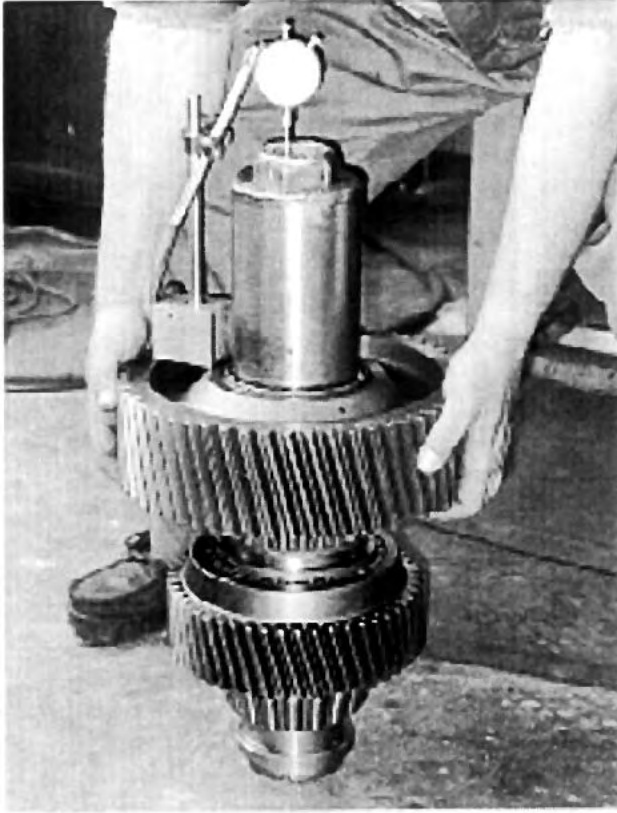

Fig. 35

1. To aid in proper reassembly, use special tool # 866 750 and note the end float of the underdrive gear assembly before disassembly. See Fig. 35.

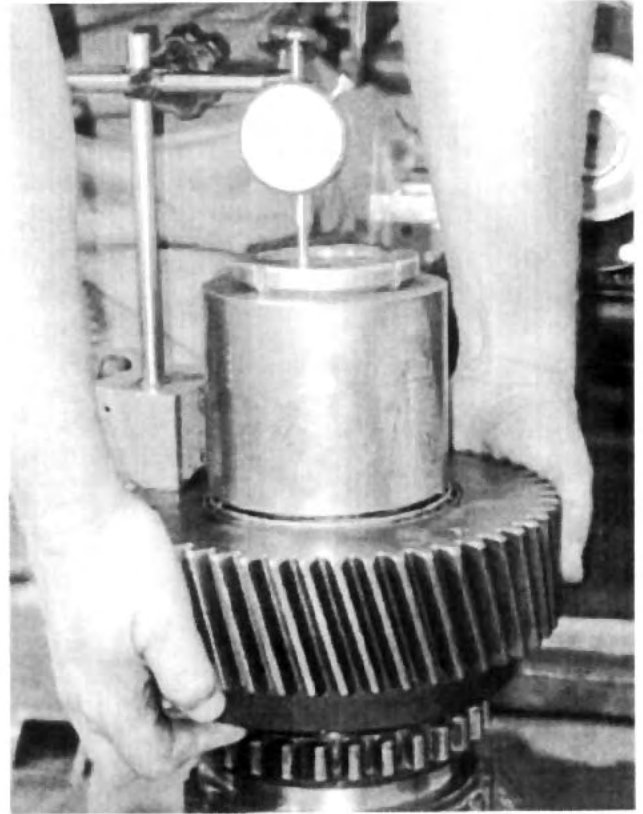

Fig. 36

2. To aid in proper reassembly, use special tool # 866 749 and note the end float of the direct drive gear assembly before disassembly. See Fig. 36.

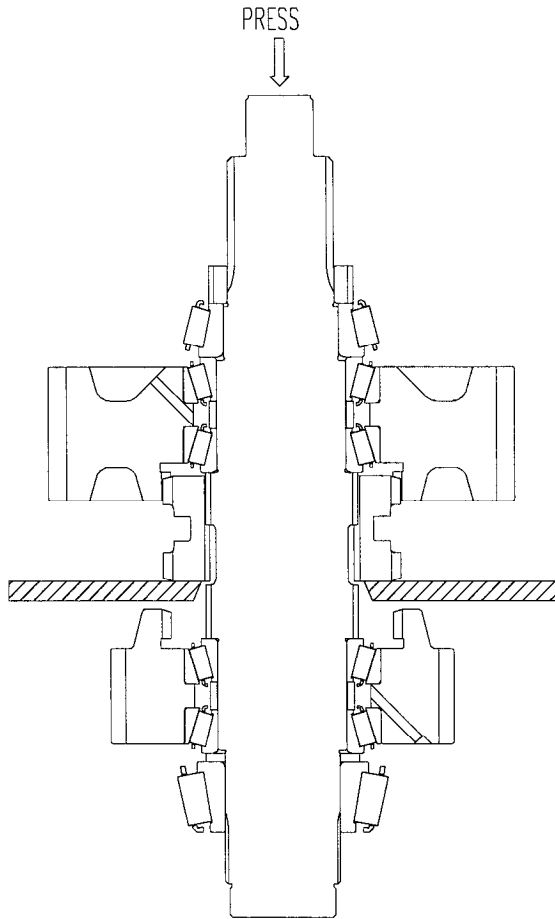

Fig. 37

3. Engage the clutch collar gear into the underdrive gear. Place the shaft assembly in a press such that the face of the clutch collar gear is supported by the separator and the press arbor is against the smaller threaded end of the shaft. *See Fig. 37.*

4. Press the shaft through the bearings, spacers, underdrive gear and clutch collar gear.

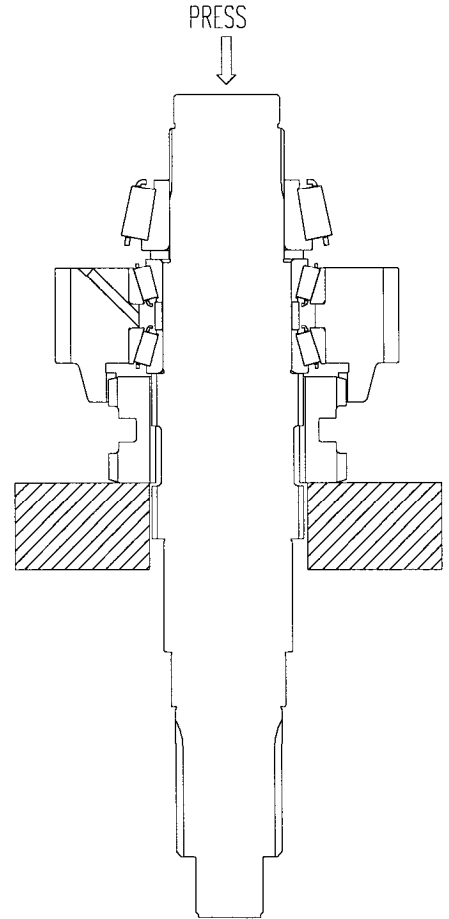

Fig. 38

5. Reinstall and engage the clutch collar gear into the direct drive gear. Place the shaft assembly in a press such that the face of the clutch collar gear is supported and the press arbor is against the larger threaded end of the shaft. *See Fig. 38.*

6. Press the shaft through the bearings, spacers, direct drive gear and clutch collar gear.

THIS CONCLUDES THE DISASSEMBLY OF THE REAR OUTPUT SHAFT

5.6 DISASSEMBLY OF THE FRONT OUTPUT SHAFT AND CARRIER

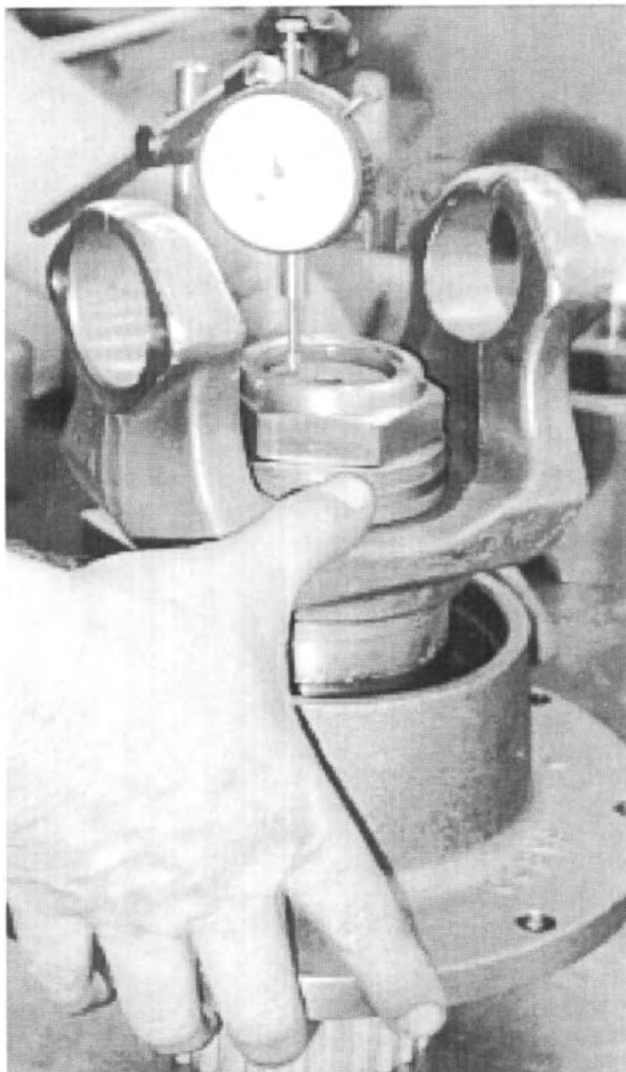

Fig. 39

1. To aid in proper reassembly, note the amount of end float of the front output shaft and carrier assembly before disassembly. *See Fig. 39.*
2. Remove the oil seal from the front output shaft carrier and discard.

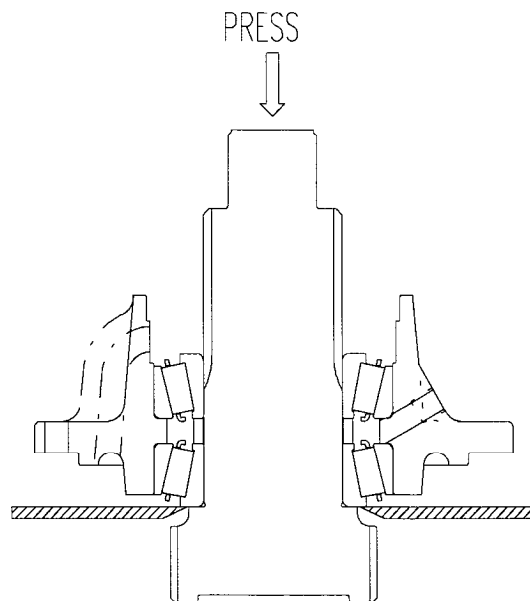

Fig. 40

3. Place the shaft assembly in a press such that the rear face of the bearing is supported by the separator and the press arbor is against the threaded end of the shaft. *See Fig. 40.*
4. Press the shaft through the carrier, bearings and spacer.
5. Remove the bearing cups from the carrier only if necessary.

THIS CONCLUDES THE DISASSEMBLY OF THE FRONT OUTPUT SHAFT AND CARRIER

6.0 ASSEMBLY

Make sure all parts are clean, dry and lint free. Any traces of storage wax or paper should be removed. Leave bearings and cups in their wrappers, until ready to use. Do not handle parts any more than necessary.

Unless indicated otherwise, part mating surfaces should be given a light coating of lubricant. Lubriplate is an acceptable grease. A substitute may be used using a mixture of chassis grease and 30W engine oil. The mix should be thin enough to apply with a small brush.

6.1 ASSEMBLY OF SUBASSEMBLIES

In the following assembly procedures, it is assumed that the various shaft assemblies were completely disassembled. Skip any step that refers to a part that is already assembled. Refer to section 4.2 in this manual for assembly precautions.

6.2 ASSEMBLY OF THE UPPER INPUT SHAFT

1. If removed during disassembly, install a new oil seal and bearing cup in the upper input shaft carrier. If removed, install a new key in the input shaft.

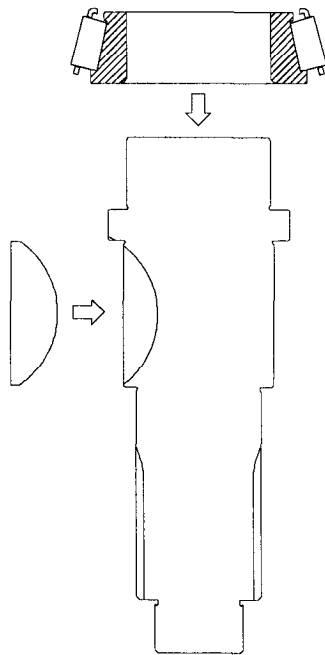

Fig. 41

2. Heat and install the bearing cone assembly against the shoulder on the non-threaded end of the upper input shaft. See Fig. 41.

CAUTION: WHEN A PART IS ASSEMBLED WITH A PRESS FIT, IT IS RECOMMENDED THAT THE PART BE HEATED PRIOR TO INSTALLATION IN A SUITABLE OVEN AT A TEMPERATURE NO GREATER THAN 300° F.

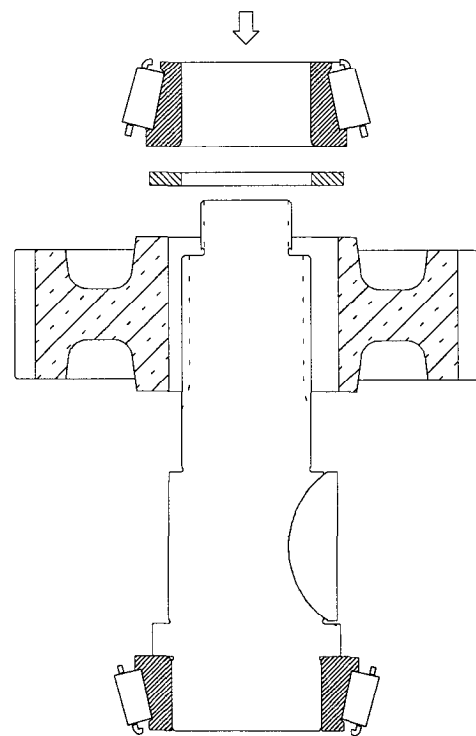

Fig. 42

3. Invert the input shaft and install the heated gear, spacer and the heated bearing cone. See Fig. 42.
4. Set aside the upper input shaft assembly in an area where it will not be damaged until the transfer case is assembled.

THIS CONCLUDES THE ASSEMBLY OF THE UPPER INPUT SHAFT

6.3 ASSEMBLY OF THE INTERMEDIATE SHAFT

1. If removed, reinstall the keys into the keyways of the intermediate shaft
2. Heat the bearing cones, intermediate direct drive gear and intermediate underdrive gear.

⚠ CAUTION: WHEN A PART IS ASSEMBLED WITH A PRESS FIT, IT IS RECOMMENDED THAT THE PART BE HEATED PRIOR TO INSTALLATION IN A SUITABLE OVEN AT A TEMPERATURE NO GREATER THAN 300° F.

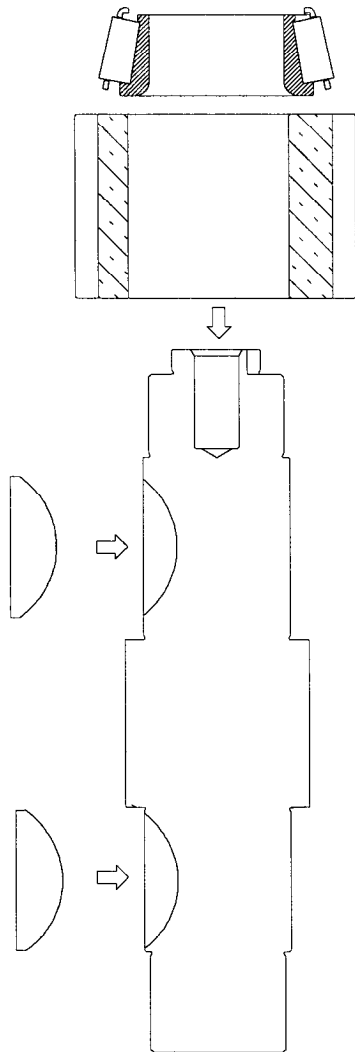

Fig. 43

3. Install the intermediate underdrive gear and bearing cone onto the intermediate shaft end with the hole. See Fig. 43.

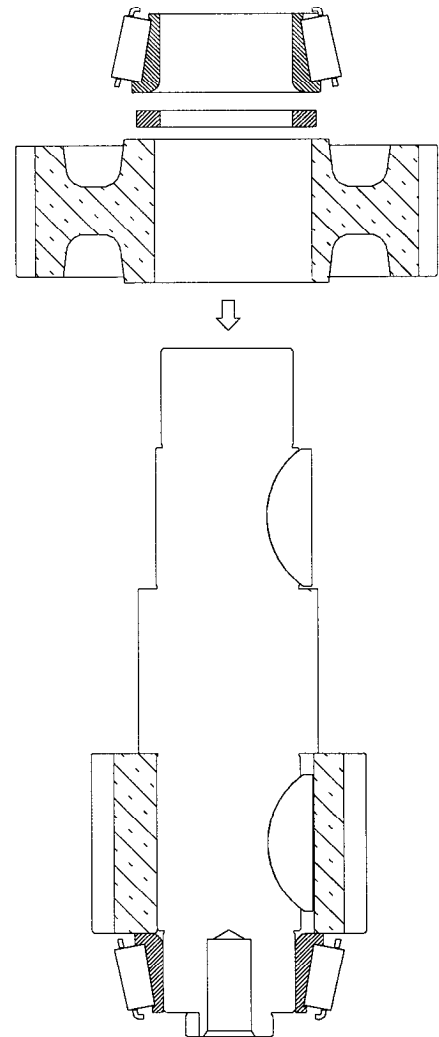

Fig. 44

4. Invert the shaft and install the intermediate direct drive gear, spacer and bearing cone. See Fig. 44.
5. Set aside the intermediate shaft assembly in an area where it will not be damaged until the transfer case is ready to be assembled.

THIS CONCLUDES THE ASSEMBLY OF THE INTERMEDIATE SHAFT

6.4 ASSEMBLY OF THE REAR OUTPUT SHAFT

1. Place the rear output shaft, with the fine-threaded end, in an upright position, protecting the shaft threads and splines.

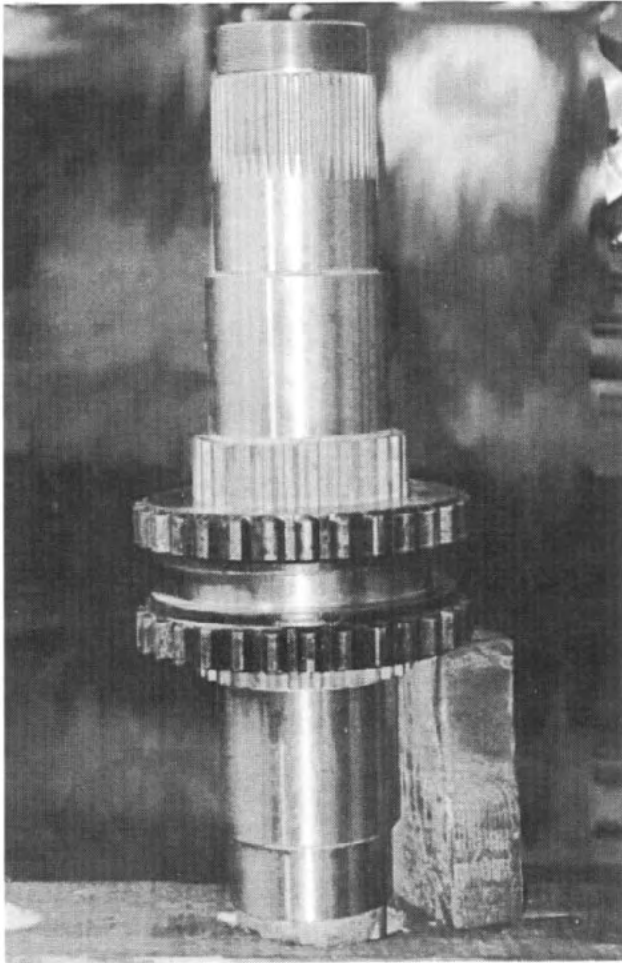

Fig. 45

2. Using a wooden block to hold the shaft in an upright position, install the clutch collar gear onto the shaft. See Fig. 45.

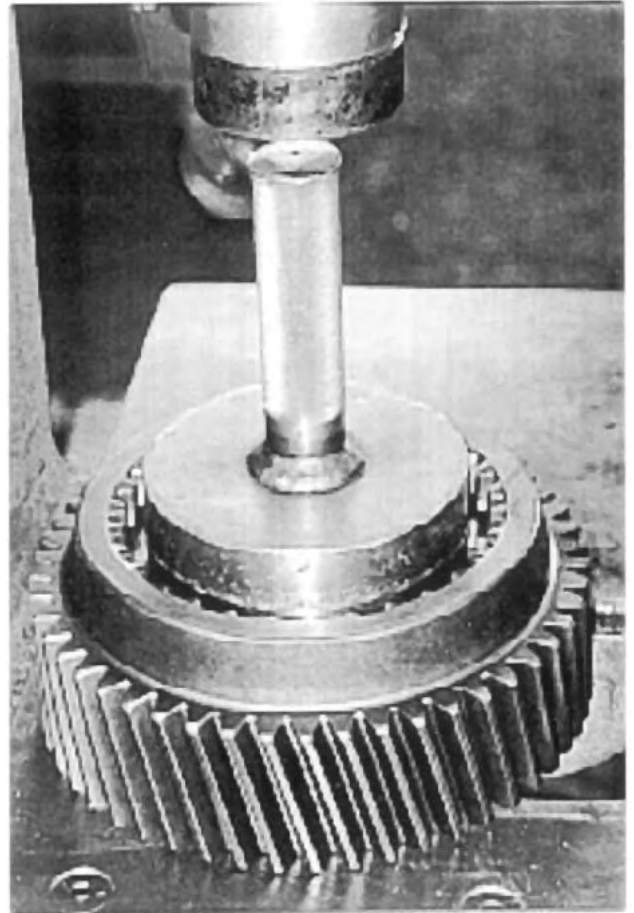

Fig. 46

3. If removed during disassembly, press the bearing cups into the lower direct drive gear. See Fig. 46.

- Heat the bearing cones in an oven.

CAUTION: WHEN A PART IS ASSEMBLED WITH A PRESS FIT, IT IS RECOMMENDED THAT THE PART BE HEATED, PRIOR TO INSTALLATION, IN A SUITABLE OVEN AT A TEMPERATURE NO GREATER THAN 300° F. HEATED COMPONENTS MUST BE ALLOWED TO COOL BEFORE END FLOAT MEASUREMENTS ARE MADE.

- Install the inner bearing cone, bearing spacer ring, lower direct drive gear and outer bearing cone, with bearing cups, onto the shaft.

- To set the lower direct drive gear end float, use special tool # 866 749 and place over the shaft. Tighten the spanner nut down using special tool # 866 687 006.

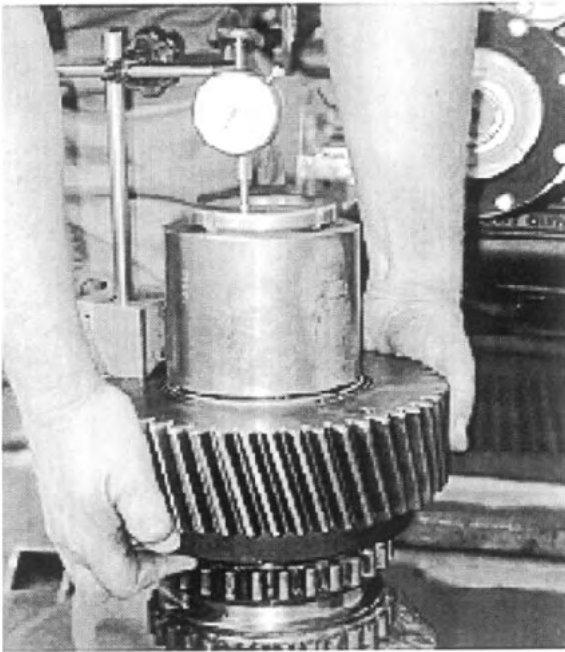

Fig. 47

- Attach a dial indicator, as shown, and record the gear float by lifting up on the lower direct drive gear. The gear float should be: **0.0005-0.0020 loose**. See Fig. 47.

- If gear end float is not within specifications, it will be necessary to disassemble the shaft and repeat steps 4-7, using a bearing spacer ring of a different thickness.

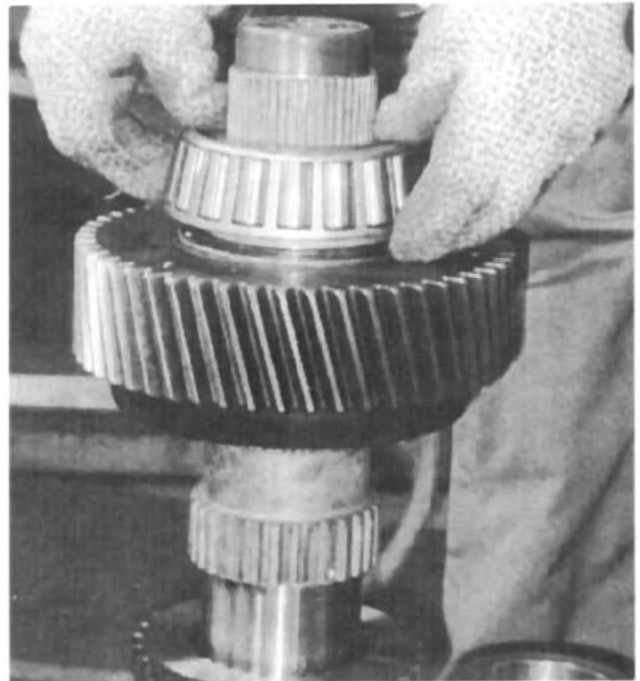

Fig. 48

- After the gear float has been set correctly, remove special tool # 866 749 and install the rear output shaft spacer, bearing cone, special tool # 866 751 and lock nut. See Fig. 48.
- Invert the rear output shaft assembly making sure that the clutch collar gear remains on the shaft.
- If removed during assembly, press the bearing cups into the lower underdrive gear.
- Heat the bearing cones in an oven.

CAUTION: WHEN A PART IS ASSEMBLED WITH A PRESS FIT, IT IS RECOMMENDED THAT THE PART BE HEATED, PRIOR TO INSTALLATION, IN A SUITABLE OVEN AT A TEMPERATURE NO GREATER THAN 300° F. HEATED COMPONENTS MUST BE ALLOWED TO COOL BEFORE END FLOAT MEASUREMENTS ARE MADE.

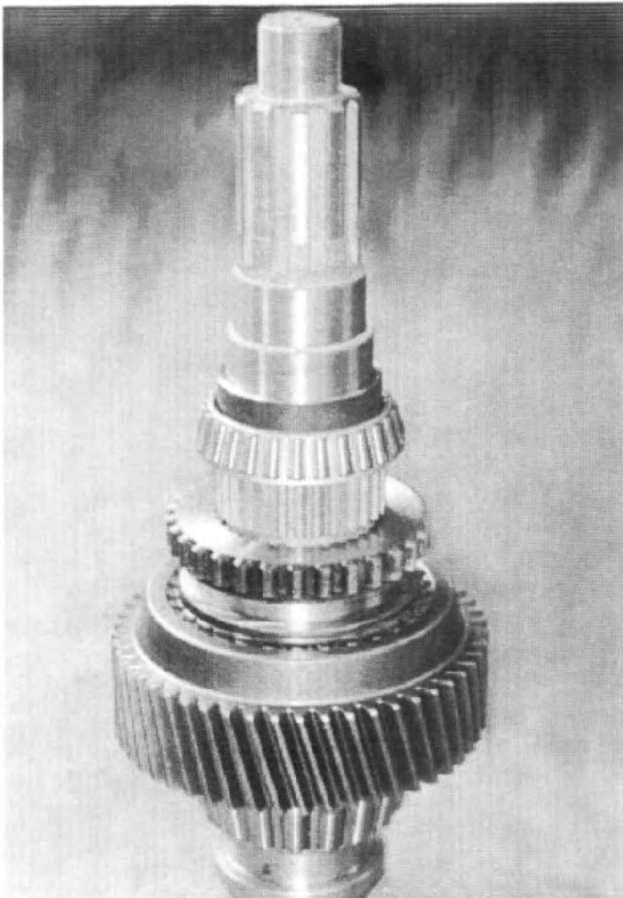

Fig. 49

13. Install the inner bearing cone onto the end of the shaft followed by the bearing spacer ring.
See Fig. 49.

14. Install the lower under drive gear, with bearing cups, followed by an outer bearing cone.

15. To set the lower underdrive gear end float, use special tool # 866 750, placed over the shaft. Tighten the lock nut down.

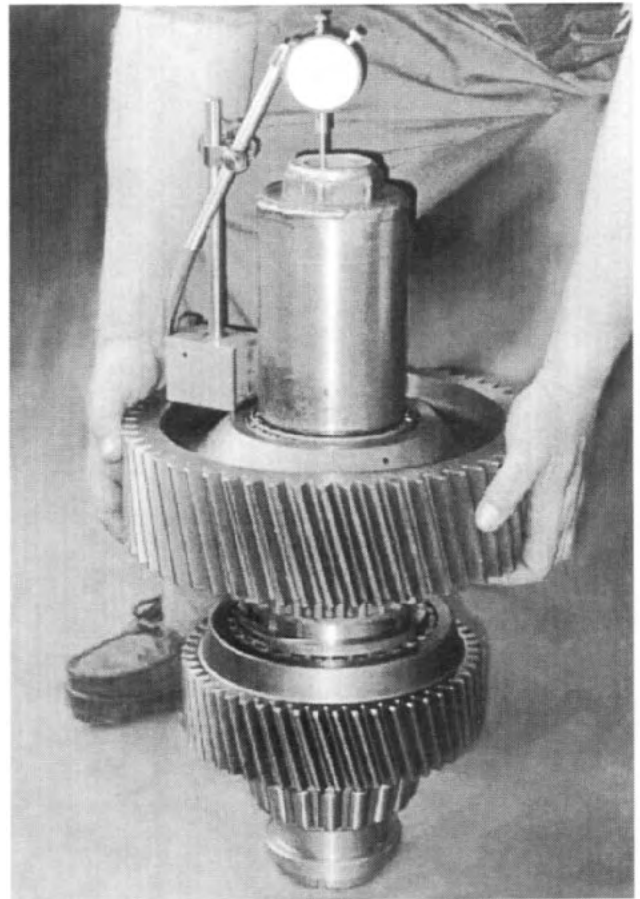

Fig. 50

16. Attach a dial indicator, as shown, and record the gear float by lifting up on the lower under drive gear. The gear float should be: **0.0005-.0020 loose**.
See Fig. 50.

17. If the gear end float is not within specifications, it will be necessary to disassemble the shaft and repeat steps 14-16 using a bearing spacer ring of a different thickness.

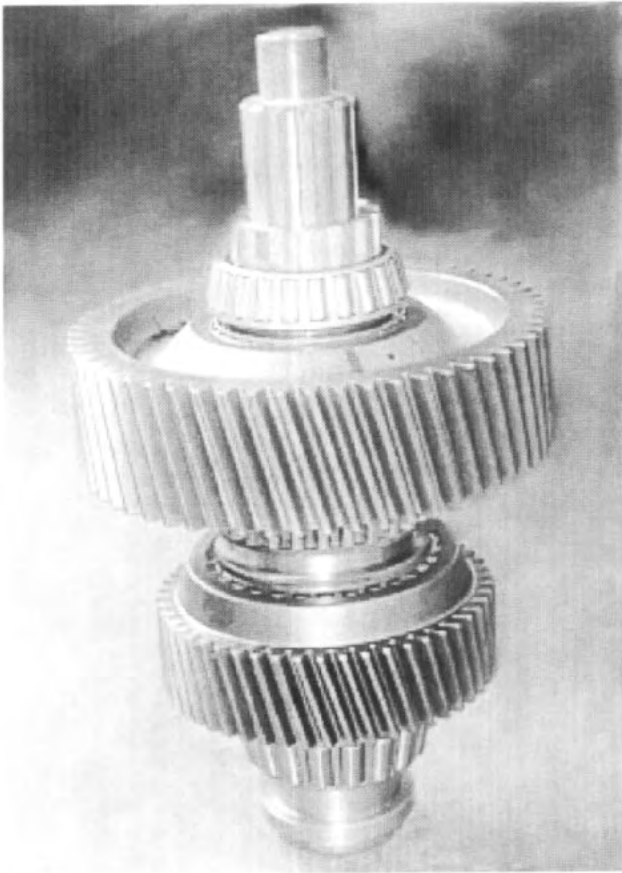

Fig. 51

18. After the gear float has been set correctly, remove special tool # 866 750 and install the rear output shaft spacer, bearing cone, electronic speedometer drive gear.

See Fig. 51.

19. Set aside the rear output shaft assembly in an area where it will not be damaged until the transfer case is ready to be assembled.

THIS CONCLUDES THE ASSEMBLY OF THE REAR OUTPUT SHAFT

6.5 ASSEMBLY OF THE FRONT OUTPUT SHAFT AND CARRIER

1. Heat and install the inner bearing cone.

CAUTION: WHEN A PART IS ASSEMBLED WITH A PRESS FIT, IT IS RECOMMENDED THAT THE PART BE HEATED, PRIOR TO INSTALLATION, IN A SUITABLE OVEN AT A TEMPERATURE NO GREATER THAN 300° F. HEATED COMPONENTS MUST BE ALLOWED TO COOL BEFORE END FLOAT MEASUREMENTS ARE MADE.

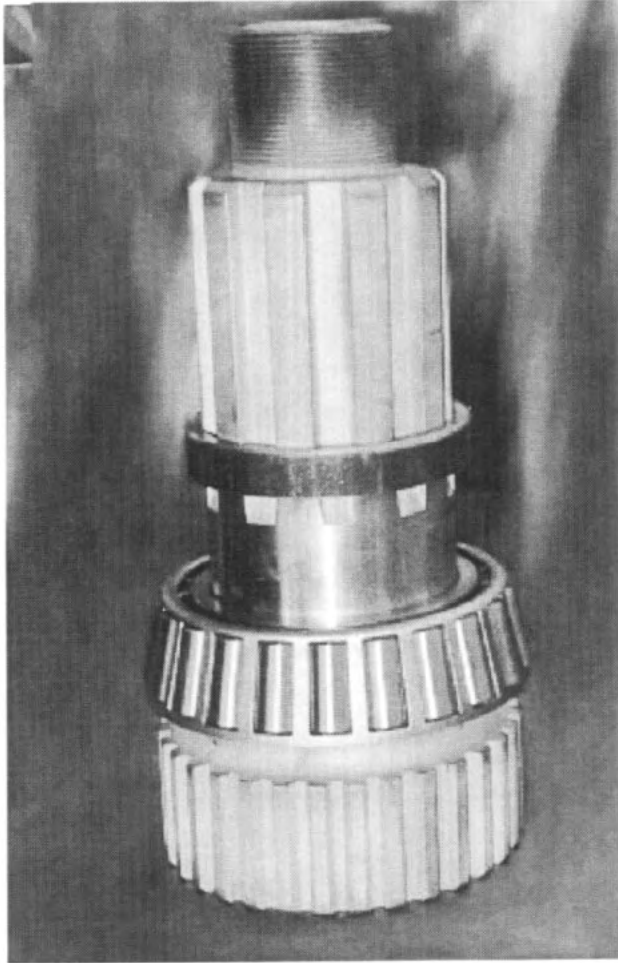

Fig. 52

2. Install the bearing spacer ring against the bearing. *See Fig. 52.*

NOTE: IF THE END FLOAT, CHECKED PRIOR TO DISASSEMBLY, WAS WITHIN THE SPECIFIED LIMITS, AND NO PARTS WERE REPLACED, THE ORIGINAL BEARING SPACER RING MAY BE REUSED.

3. Press the bearing cups into the carrier.

4. Install the front output shaft into the carrier.

5. Heat and install the outer bearing cone.

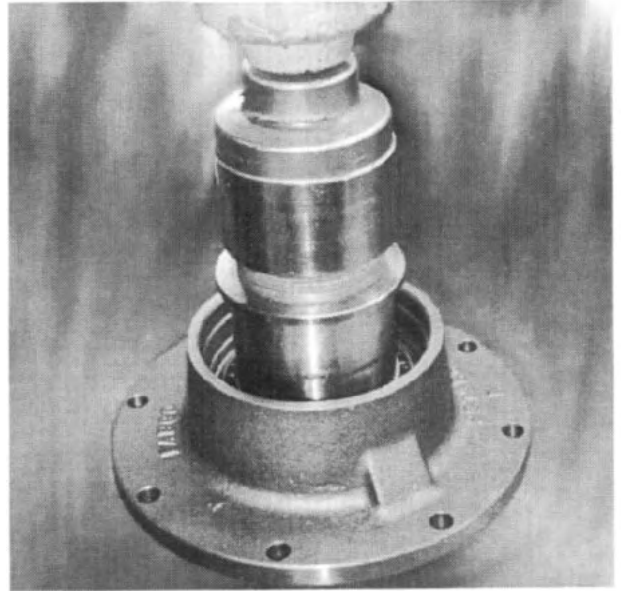

Fig. 53

6. To check shaft end float, install special tool # 866 751. Tighten the lock nut down. *See Fig. 53.*

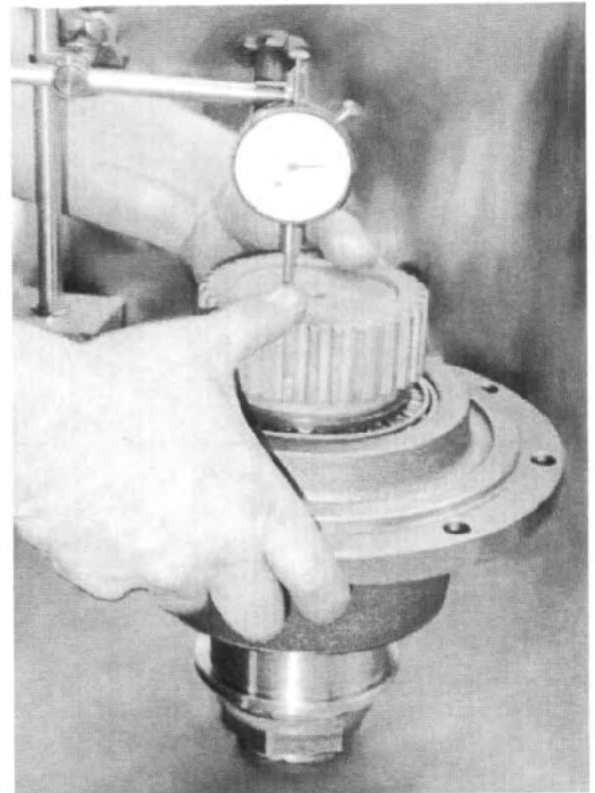

Fig. 54

7. Attach a dial indicator, as shown, and record the shaft end float by lifting up on the carrier. The shaft end float should be: **0.003-0.008 loose**. *See Fig. 54.*

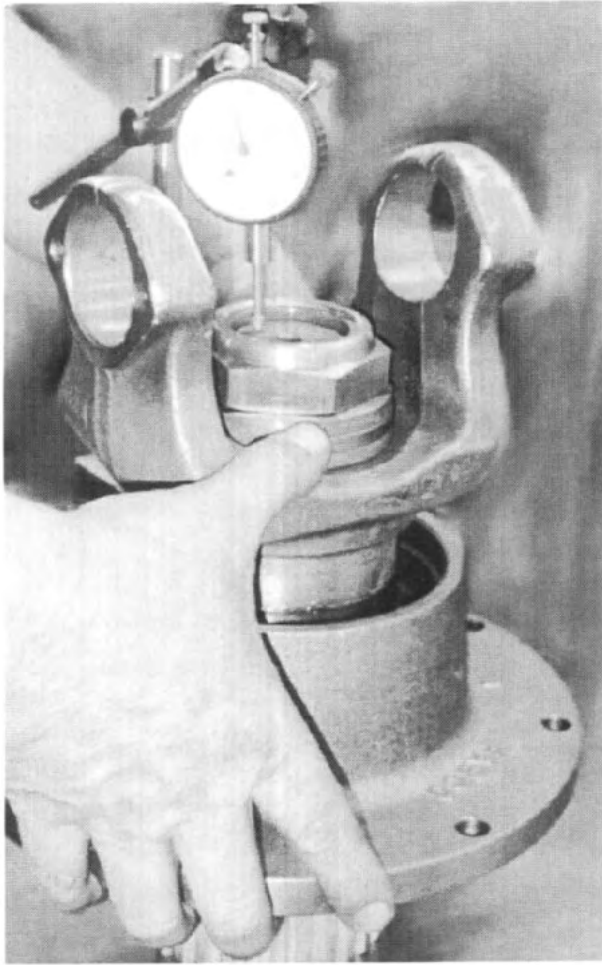

Fig. 55

NOTE: IF SPECIAL TOOL # 866 751 IS NOT AVAILABLE, IT IS PERMISSIBLE TO USE THE FRONT OUTPUT SHAFT YOKE TO ACCOMPLISH THE SAME TASK. See Fig. 55.

8. If the shaft end float is not within specifications, the carrier assembly will have to be disassembled and steps 2-7 repeated using a bearing spacer ring of a different thickness.

9. After the specified shaft end float is obtained, remove the locknut and special tool # 866 751. Install a new oil seal in the front output carrier.

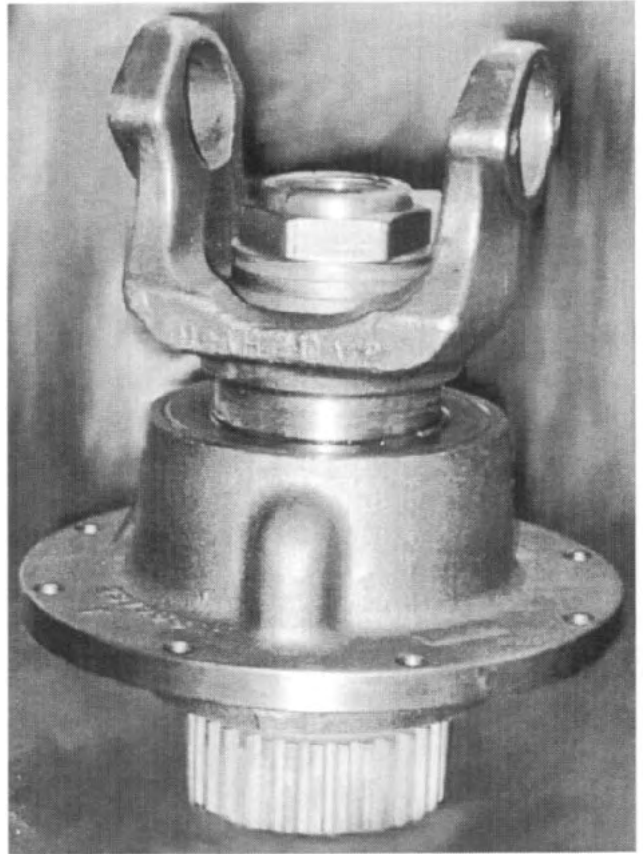

Fig. 56

10. Reinstall the yoke and locknut, torquing the locknut to the specified limit. See Fig. 56.

11. Set aside the front output shaft and carrier assembly in an area where it will not be damaged until the transfer case is ready to be assembled.

THIS CONCLUDES THE ASSEMBLY OF THE FRONT OUTPUT SHAFT AND CARRIER

6.6 GENERAL ASSEMBLY



Fig. 57



Fig. 58

1. If removed, install bearing cups into the transfer case housing front bores for the intermediate and rear output shafts. *See Fig. 57-58.*

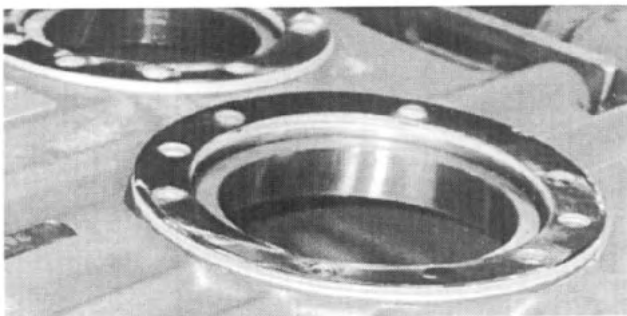

Fig. 59

2. Place the stack of shims, removed during disassembly, on the intermediate and rear output shaft bores of the transfer case housing. *See Fig. 59.*

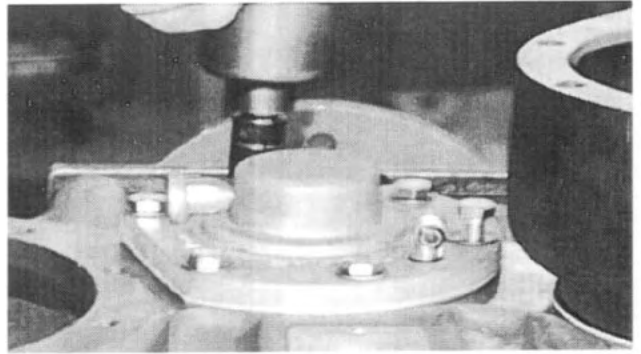

Fig. 60

3. Install the intermediate front cap to the transfer case. Tighten, but do not torque the bolts at this time. *See Fig. 60.*

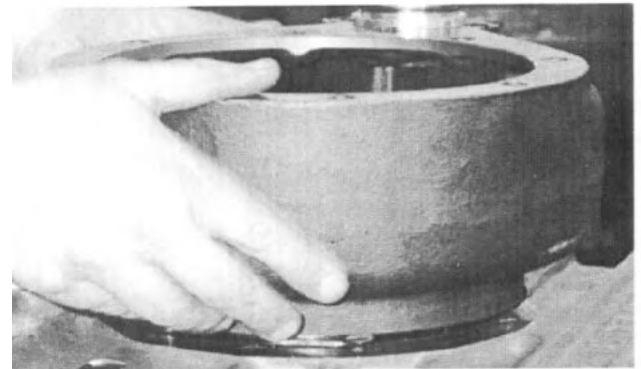

Fig. 61

4. Install the front drive declutch housing, noting its proper orientation (refer to Fig. 107). Tighten, but do not torque the bolts at this time. *See Fig. 61.*



Fig. 62

5. Turn the transfer case over. Install the Intermediate shaft assembly, direct drive gear down, into the transfer case. *See Fig. 62.*

6. Install a new locking plate between the fork and jam nut of the shifter fork assembly.

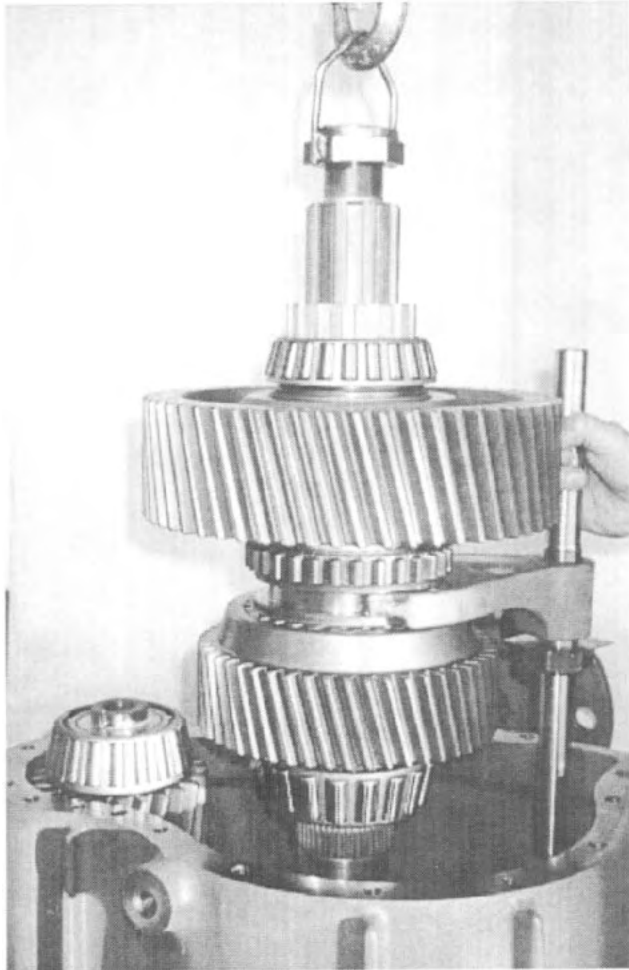

Fig. 63

7. Install the shifter shift fork assembly onto the rear output shaft assembly. Make sure that the flat side of the shift fork faces the underdrive gear. See Fig. 63.

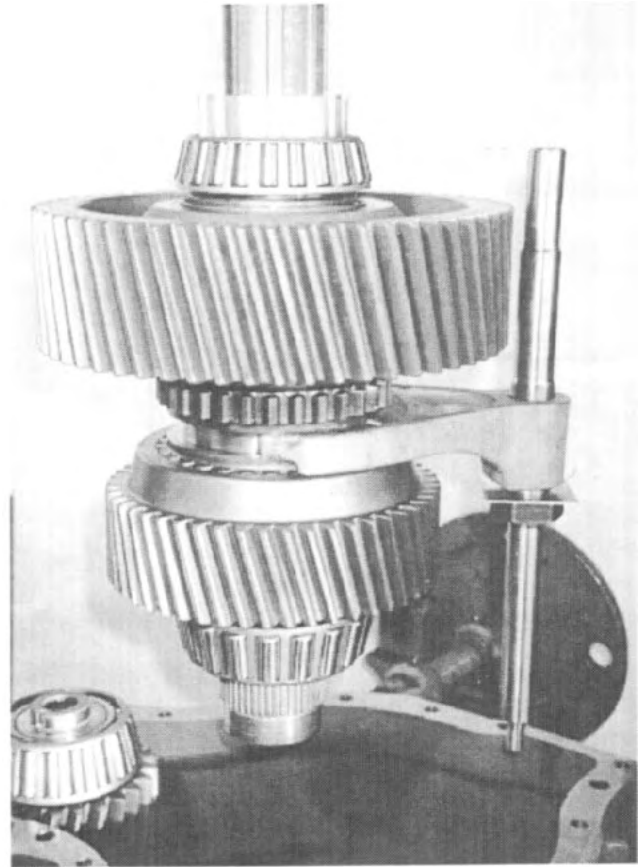

Fig. 64

8. Install the rear output shaft and shifter shaft fork assembly into the transfer case housing. See Fig. 64.

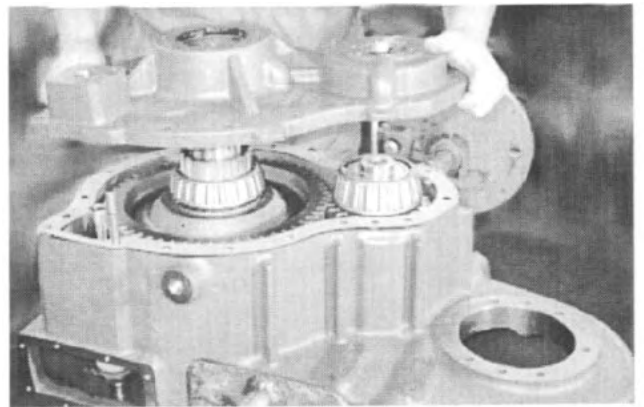

Fig. 65

9. If removed during disassembly, install two (2) new short dowl pins into the transfer case housing. Place a new rear carrier gasket onto the machine surfaces of the transfer case housing. Install the rear carrier, with bearing cups, onto the transfer case. Make sure the shifter shaft fork assembly is properly aligned. See Fig. 65.



Fig. 66

10. Install the carrier attaching hardware and torque to specifications. *See Fig. 66.*



Fig. 67

11. Install a rear output seal and the drive yoke. Tighten the locknut to the specified torque. *See Fig. 67.*

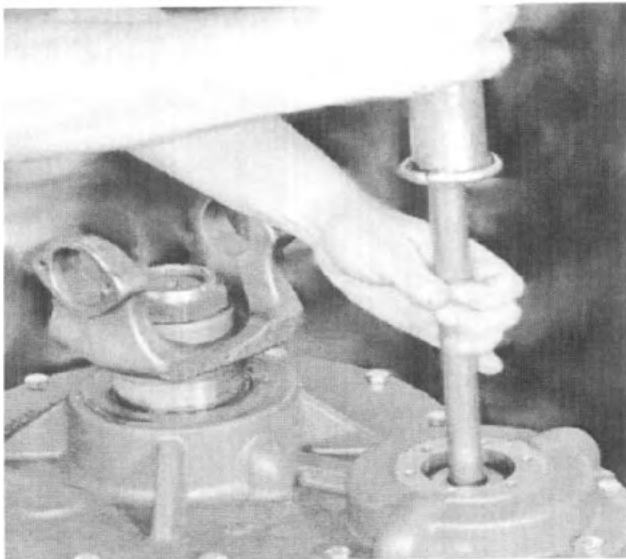

Fig. 68

12. Gently tap the end of the intermediate shaft to properly seat it in the housing. *See Fig. 68.*

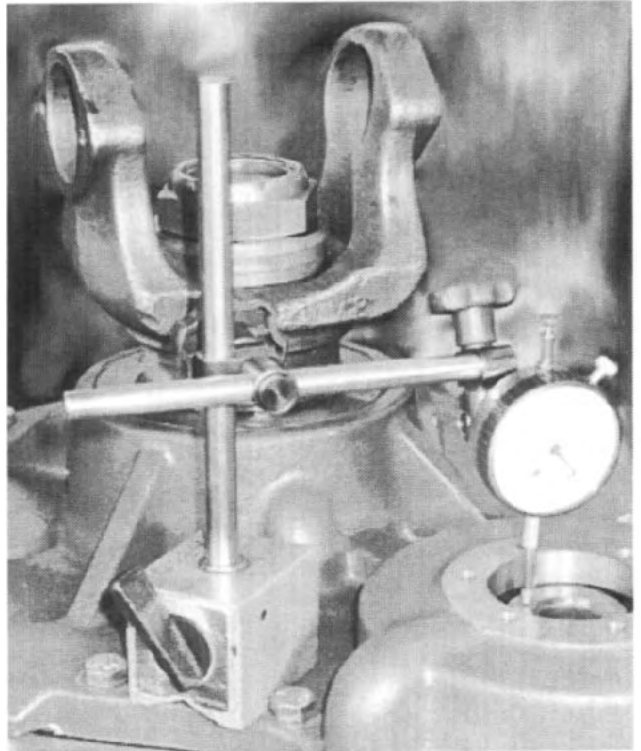

Fig. 69

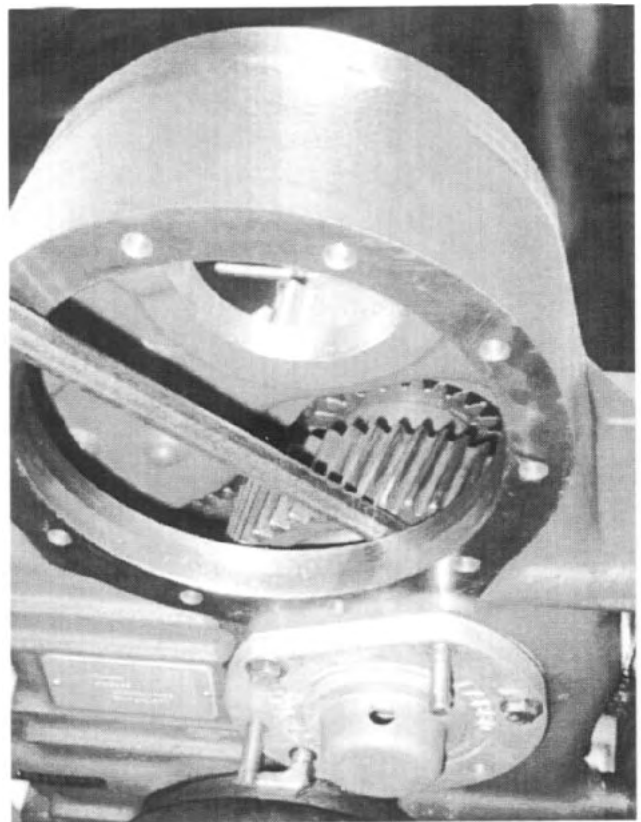

Fig. 70

13. Attach a dial indicator onto a flat area of the rear carrier and check the shaft's end float by carefully prying up on the intermediate shaft from underneath the transfer case. The end float should read: **0.003-0.008 loose**. *See Figs. 69-70.*

NOTE: IF THE END FLOAT IS NOT WITHIN SPECIFICATION, **0.003-0.008 loose**, THE SHIM PACK SHOULD BE REMOVED AND REPLACED WITH A SHIM COMBINATION WHICH WILL PROVIDE THE PROPER END FLOAT.

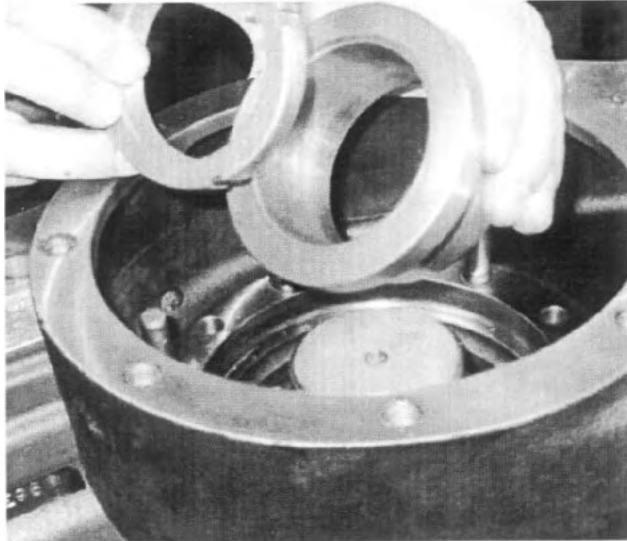

Fig. 71

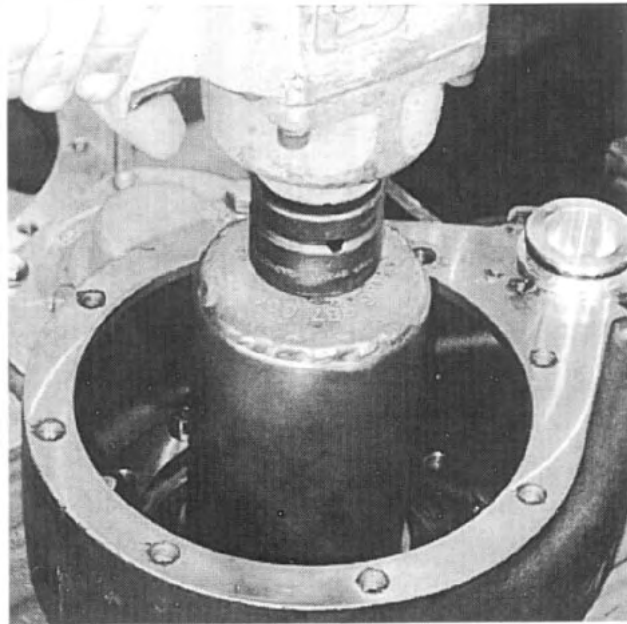

Fig. 72

14. Turn over the transfer case. Install special tool # 866 751 onto the end of the rear output shaft. Install the bearing lock nut, using special tool # 866 687 006. See Figs. 71-72.

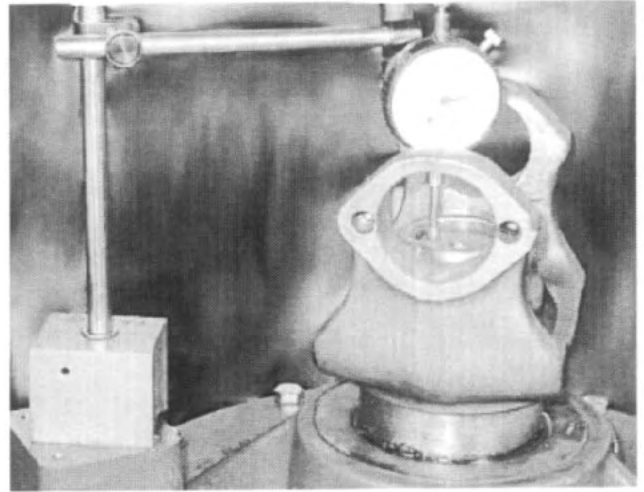

Fig. 73

15. Turn the transfer case over. Attach a dial indicator onto a flat area of the rear carrier, adjacent to the rear output shaft yoke. Check the end float on the rear output shaft. The end float should read: **0.003-0.008 loose**. See Fig. 73.

NOTE: IF THE END FLOAT IS NOT WITHIN SPECIFICATION, **0.003-0.008 LOOSE**, THE SHIM PACK SHOULD BE REMOVED AND REPLACED WITH A SHIM COMBINATION WHICH WILL PROVIDE THE PROPER END FLOAT.

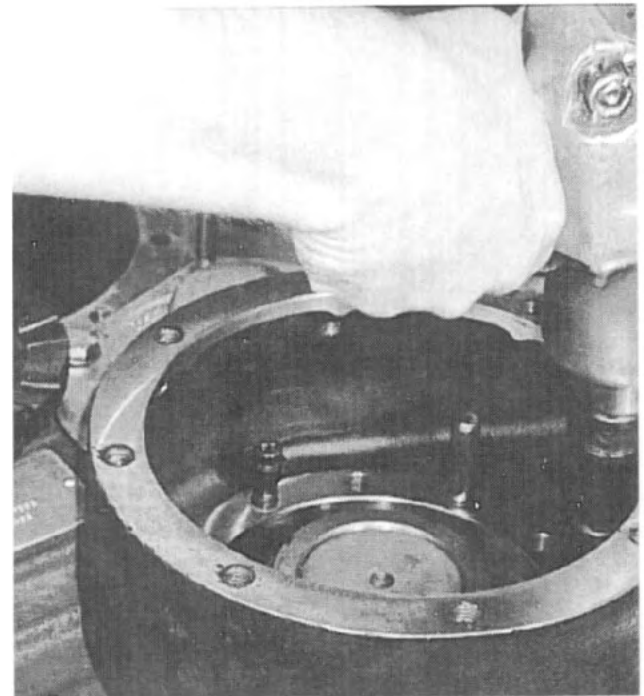

Fig. 74

16. Torque the declutch housing attachment bolts to specifications. See Fig. 74.

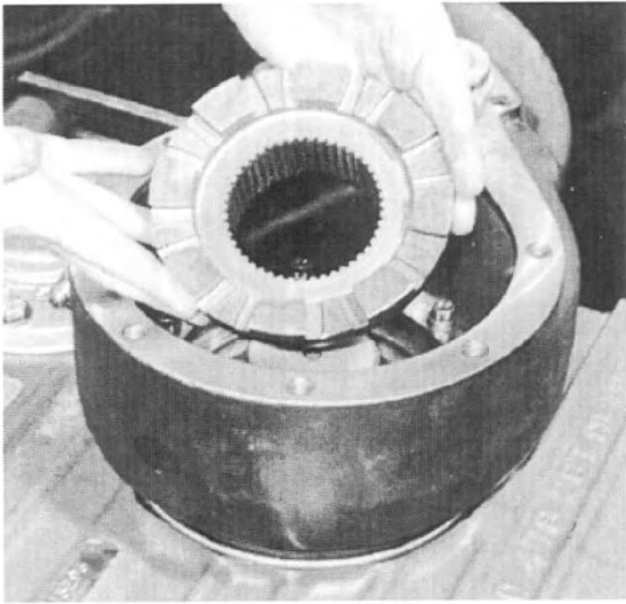

Fig. 75

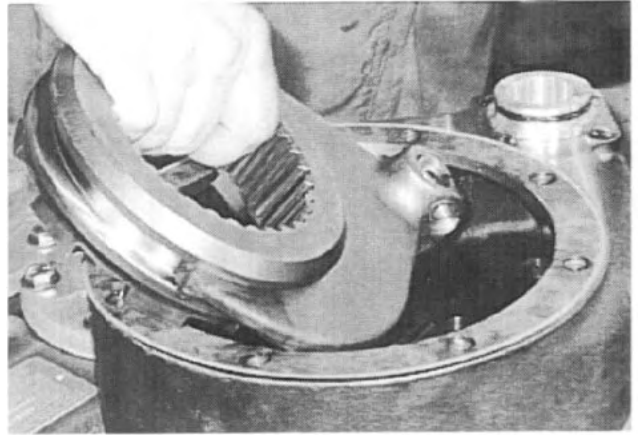

Fig. 77

18. Install the front declutch shift fork and front declutch sliding gear into the declutch housing. See Fig. 77.

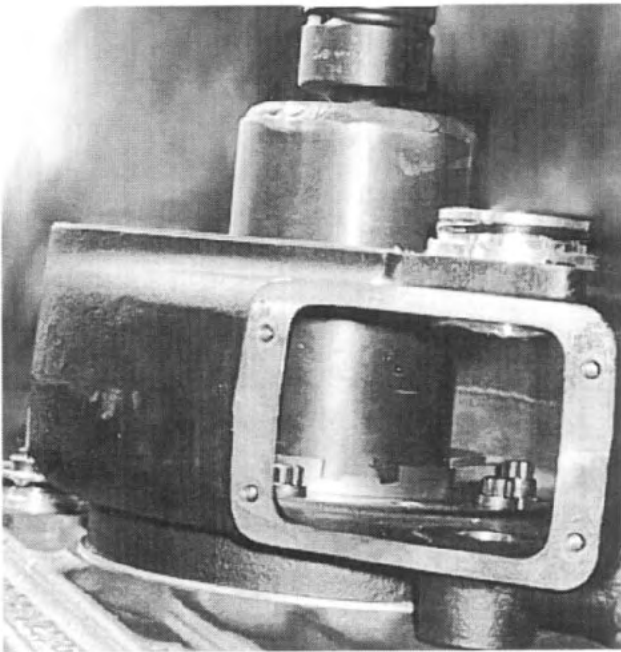

Fig. 76

17. Using special tool # 866 687 006, remove the bearing locknut on the rear output shaft. Remove special tool # 866 751. Install the front declutch fixed gear and the bearing lock nut. Torque to specification. See Figs. 75-76.

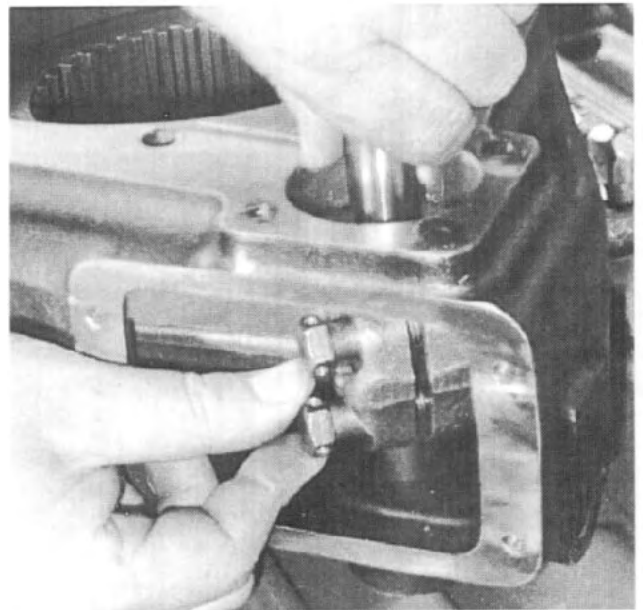

Fig. 78

19. Install the front drive shifter shaft into the declutch housing, attaching it to the front declutch shift fork with two (2) special 7/16-20 bolts. See Fig. 78.

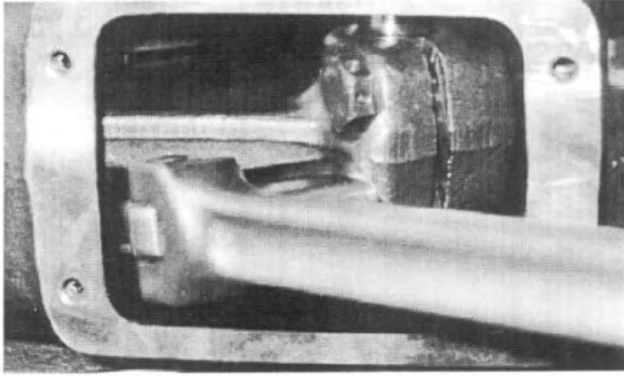

Fig. 79

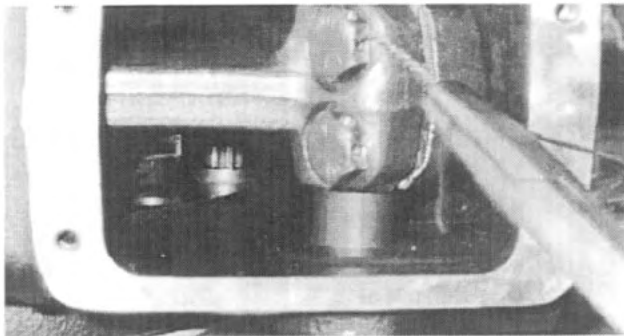

Fig. 80

20. Torque the shift shaft bolts to specification and lockwire. *See Figs. 79-80.*

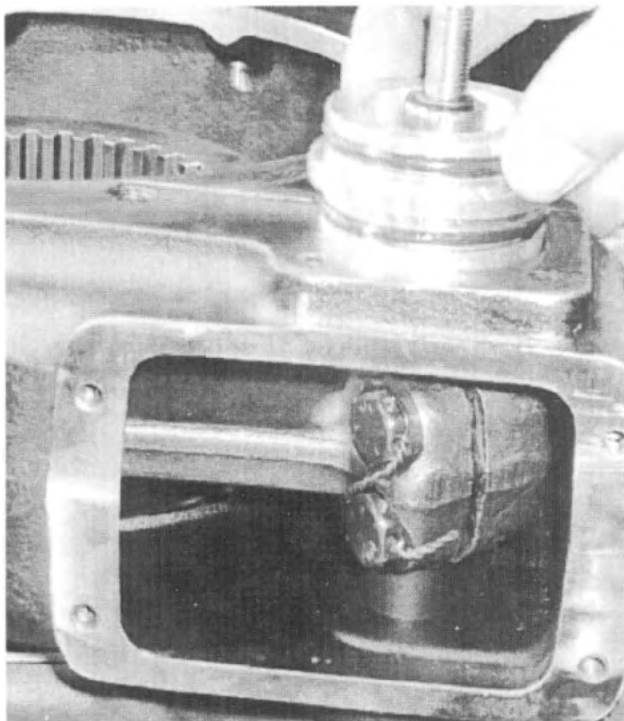

Fig. 81

21. Install the front declutch shift cylinder adapter into the declutch housing, using new o-rings. *See Fig. 81.*



Fig. 82

22. Install the front drive shift spring, plastic adjusting washer(s) and piston, using a new o-ring. *See Fig. 82.*



Fig. 83

23. Compress the shift spring, by pushing down on the piston, and install a 3/8-24 lock nut onto the end of the shift shaft. Torque the lock nut to specification. *See Fig. 83.*



Fig. 84

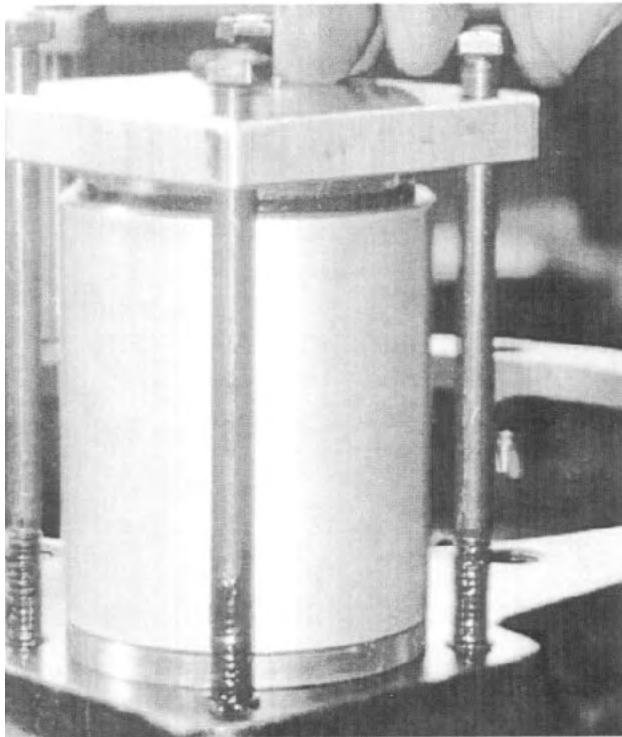

Fig. 85

24. Install a new oil-soaked felt wiper onto the piston. Install the cylinder and cap over the piston. Secure the assembly with four (4) 1/4-20 bolts, torquing to specification. *See Figs. 84-85.*

⚠ WARNING: WHEN INSTALLING THE CYLINDER OVER THE PISTON ASSEMBLY, EXERCISE CAUTION NOT TO NICK THE O-RINGS OR DISTORT THE FELT WIPER. FAILURE TO DO SO COULD RESULT IN A LEAKING FRONT DECLUTCH SHIFT CYLINDER.

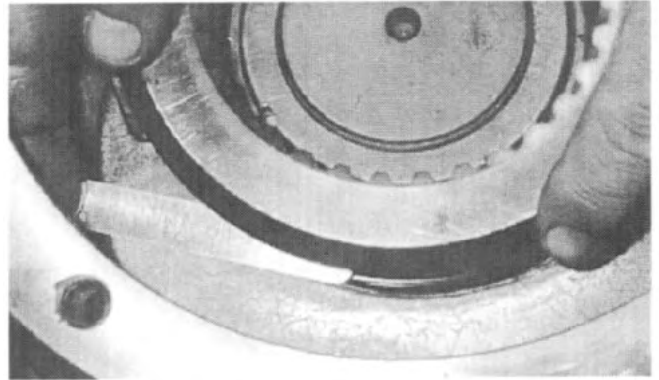

Fig. 86

25. Manually align the fixed and sliding clutch gears. Apply air pressure (100 psi) to the front drive declutch shift cylinder. Check with feeler gages that there is a minimum of **0.005" clearance** between both sides of the shift fork and the sliding clutch gear groove. If this is not met, the air shift cylinder must be disassembled and an additional plastic washer (0.030" thick) must be installed. *See Fig. 86.*

⚠ CAUTION: DO NOT REACH INTO THE DECLUTCH HOUSING WHEN APPLYING AIR PRESSURE TO THE DECLUTCH SHIFT CYLINDER.

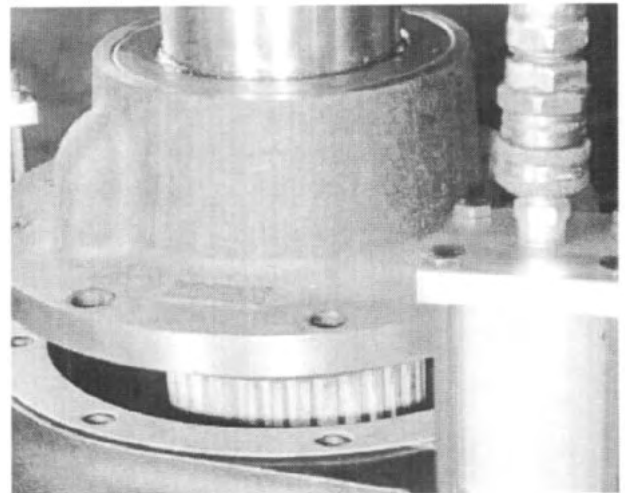

Fig. 87

26. With air pressure still applied, install a new gasket onto the declutch housing. Install the front output shaft and carrier assembly. Torque the attachment hardware to specification. *See Fig. 87.*

NOTE: THE OIL DRAIN CAVITY ON THE CARRIER MUST BE IN THE 6 O'CLOCK (BOTTOM) POSITION. THE OIL FITTING IS IN THE 10 O'CLOCK POSITION. Refer to Fig. 107.

27. If removed, install a bearing cup into the transfer case housing upper rear bore.

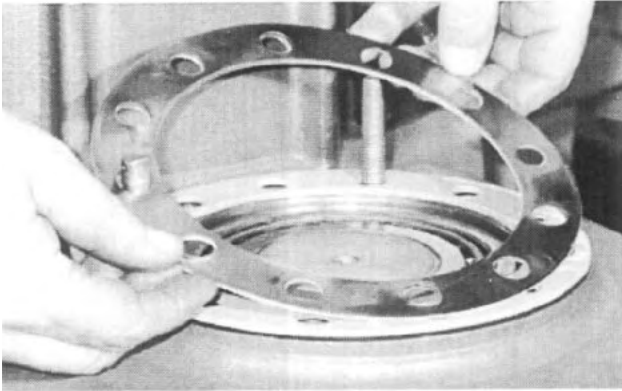

Fig. 88

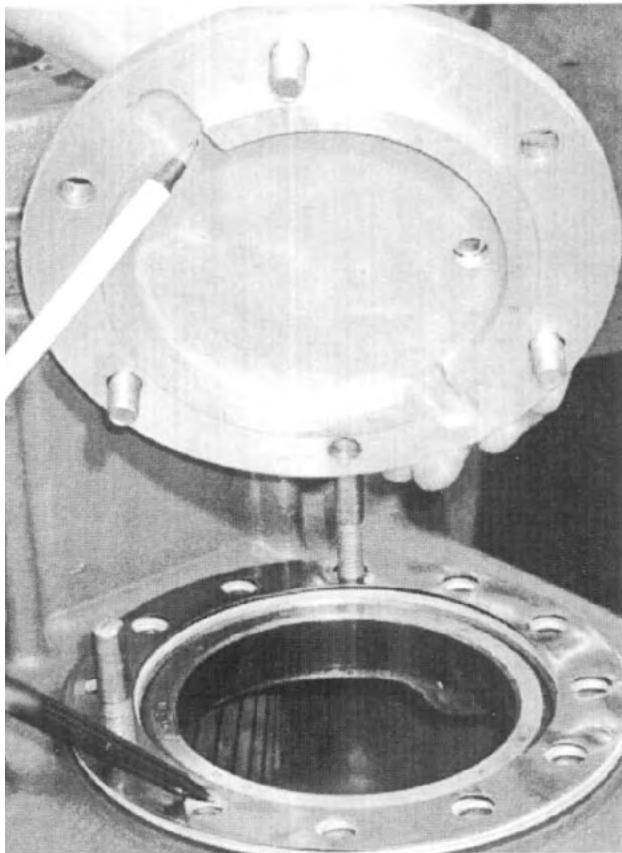

Fig. 89

28. Place the stack of shims, removed during disassembly, on the rear input shaft bore of the transfer case housing. Install the top rear cap, noting the alignment of the oil grooves in the cap with the oil gallery holes in the transfer case housing. Tighten, but do not torque the cap bolts at this time. See Figs. 88-89.

WARNING: FAILURE TO PROPERLY ALIGN THE CAP WITH THE TRANSFER CASE COULD LEAD TO LUBRICATION BLOCKAGE OF THE UPPER INPUT SHAFT.

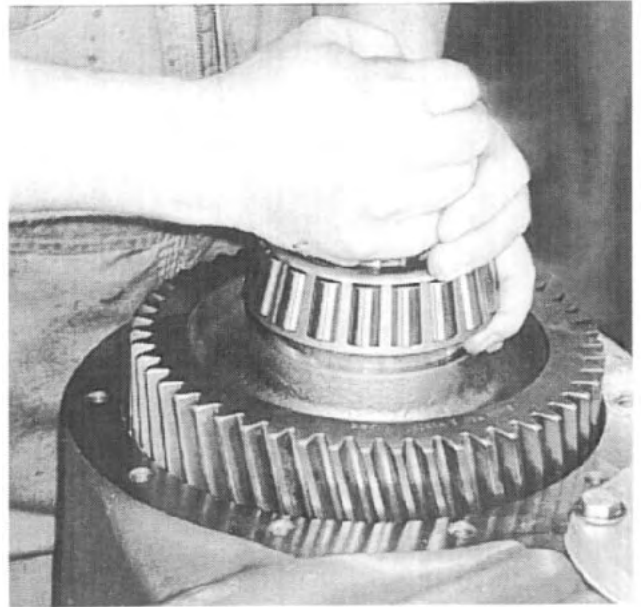

Fig. 90

29. Turn the transfer case over. Install the front input shaft assembly, threaded end up, into the transfer case housing. See Fig. 90.

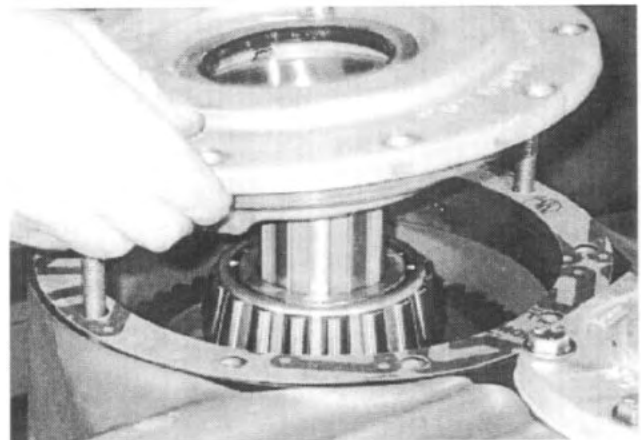

Fig. 91

30. Install a new gasket. If removed, install a new seal into the input carrier. Install the input carrier assembly onto the transfer case. Install and torque to specifications the input carrier hardware. See Fig. 91.

CAUTION: THE WORD "TOP", ON THE CARRIER, MUST LINE UP WITH THE TOP OF THE TRANSFER CASE HOUSING. FAILURE TO DO SO WILL RESULT IN LUBRICATION BLOCKAGE TO THE UPPER INPUT SHAFT.

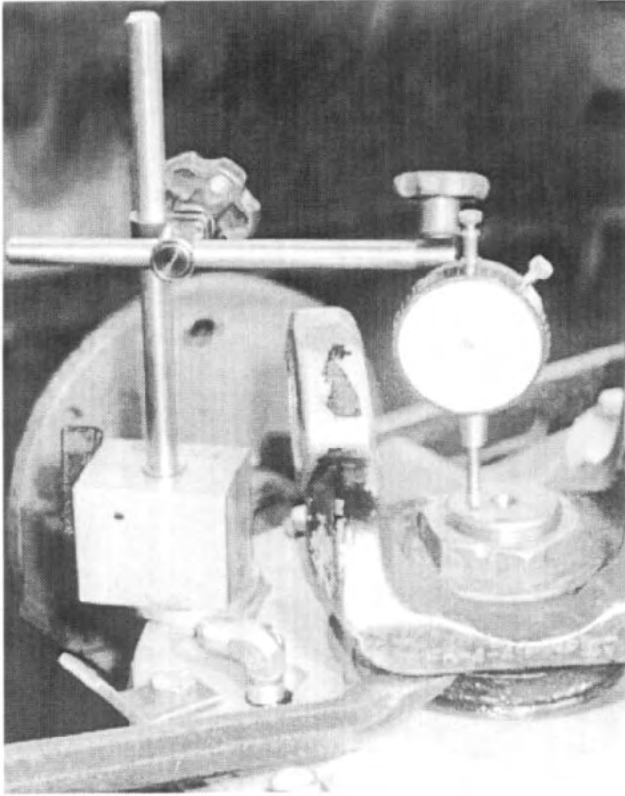

Fig. 92

31. Install the input shaft yoke. Using a dial indicator, and gently prying upwards the input shaft yoke, check that the end float is: **0.003-0.008 loose**. Torque to specification. See Fig. 92.

NOTE: IF THE END FLOAT IS NOT WITHIN SPECIFICATION, **0.003-0.008 loose**, THE SHIM PACK SHOULD BE REMOVED AND REPLACED WITH A SHIM COMBINATION WHICH WILL PROVIDE THE PROPER END FLOAT.

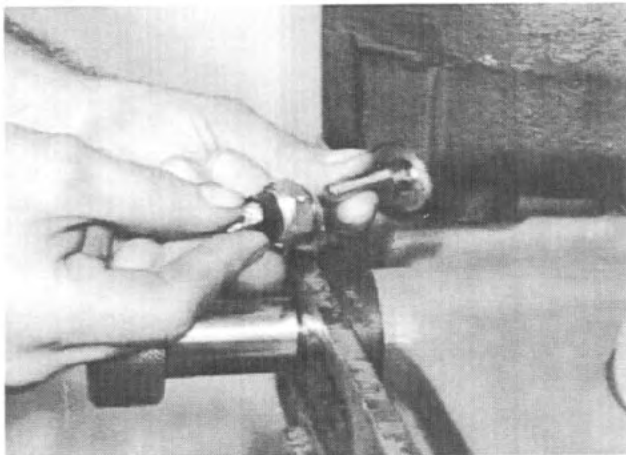

Fig. 93

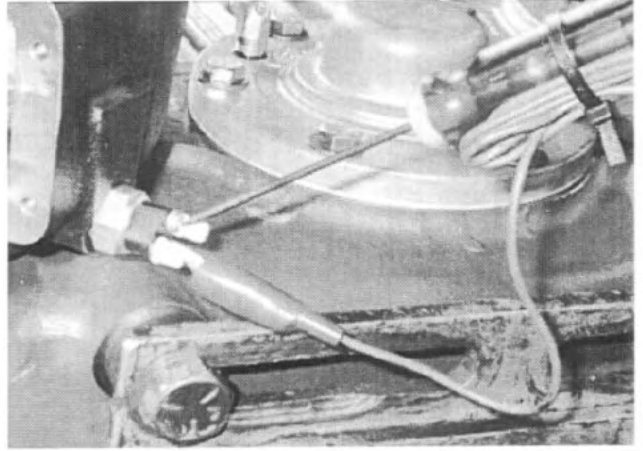

Fig.94

32. Install the sensor pin, the shift indicator light switch and two (2) copper washers into the declutch housing. The rounded end of the sensor pin must face inward. Check for continuity across the leads of the sensor with a continuity tester. The tester should indicate a closed circuit condition with air pressure applied to the air shift cylinder. See Figs. 93-94.

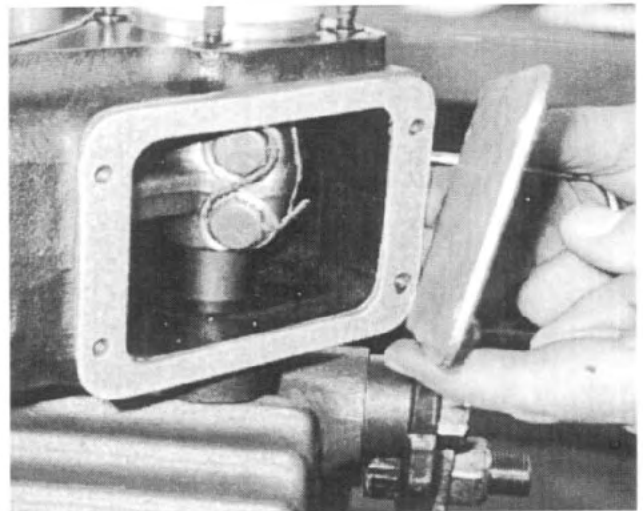

Fig. 95

33. Using a new gasket, secure the declutch housing cover plate with four (4) 1/4-20 bolts. Torque to specification. See Fig. 95.

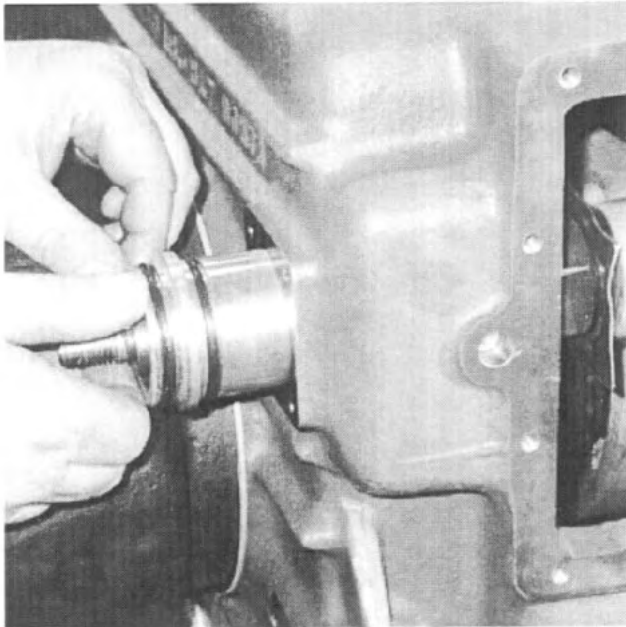

Fig. 96

34. Using a new o-ring, insert the adapter tube for the high-low shift cylinder into the transfer case. See Fig. 96.

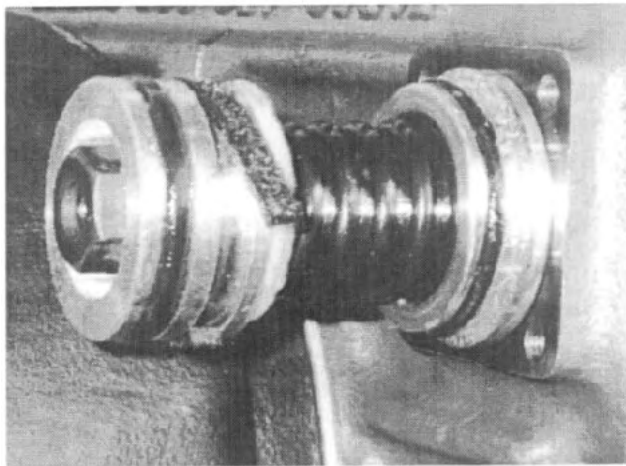

Fig. 97

35. Install the piston stop rings, high-low shift spring and the high-low shift piston (with a new o-ring) on the end of the high-low shifter shaft. Compress the spring with the piston and secure with a 1/2-13 lock nut. See Fig. 97.

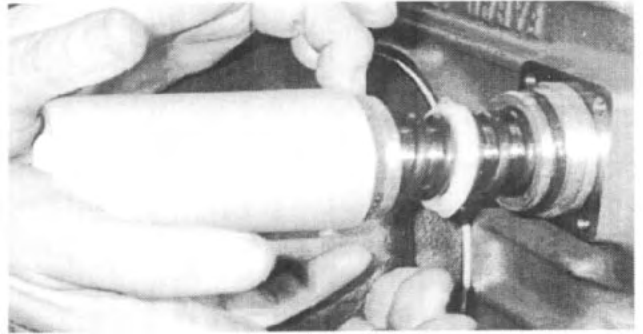

Fig. 98

36. Install a new oil-soaked felt wiper onto the piston assembly. Install the cylinder housing over the piston assembly. See Fig. 98.

⚠ WARNING: WHEN INSTALLING THE CYLINDER OVER THE PISTON ASSEMBLY, EXERCISE CAUTION NOT TO NICK THE O-RINGS OR TO DISTORT THE FELT WIPER. FAILURE TO DO SO COULD RESULT IN A LEAKING HIGH-LOW SHIFT CYLINDER.

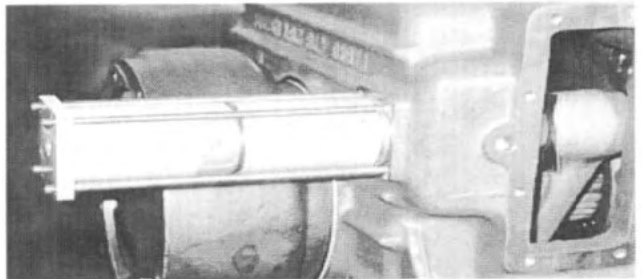

Fig. 99

37. If equipped with neutral, install the outer half of the shift cylinder onto the high-low shift cylinder. Secure the assembly with four (4) 1/4-20 studs and nuts. Torque to specification. See Fig. 99.

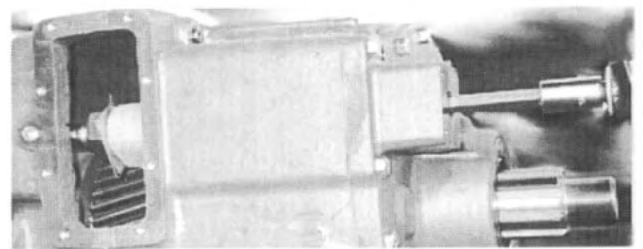

Fig. 100

38. Insert a 7/16" Allen wrench into the adjustment hole on the opposite end of the high-low shift shaft. Turn the shaft until the sliding clutch gear bottoms out or touches the bearing cone inside the lower direct drive gear. Back off one (1) complete turn to set the adjustment. See Fig. 100.

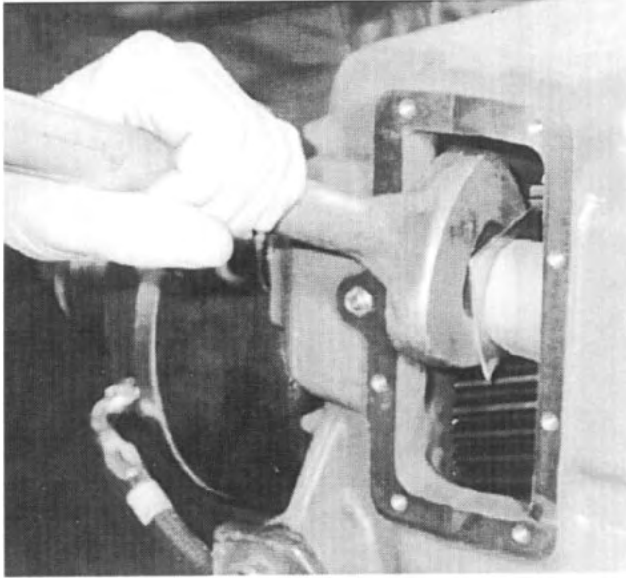

Fig. 101

39. Tighten the lock nut against the high-low shift fork. See Fig. 101.

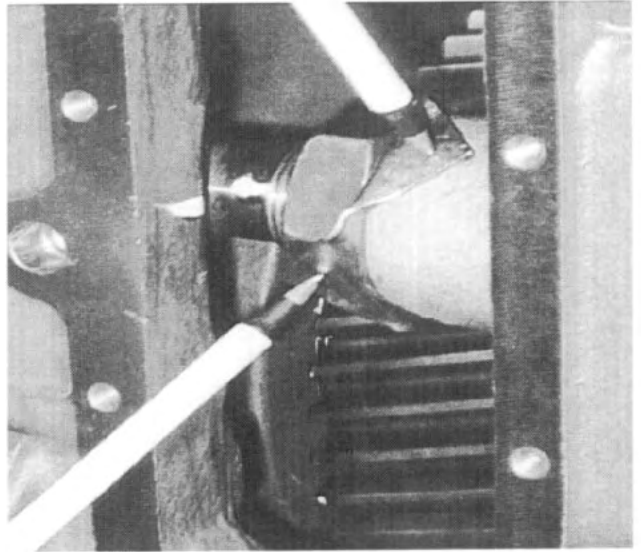

Fig. 103

40. Safety-lock the lock nut by bending the tabs of the steel locking plate over the flats of the nut and the shift fork. See Figs. 102-103.

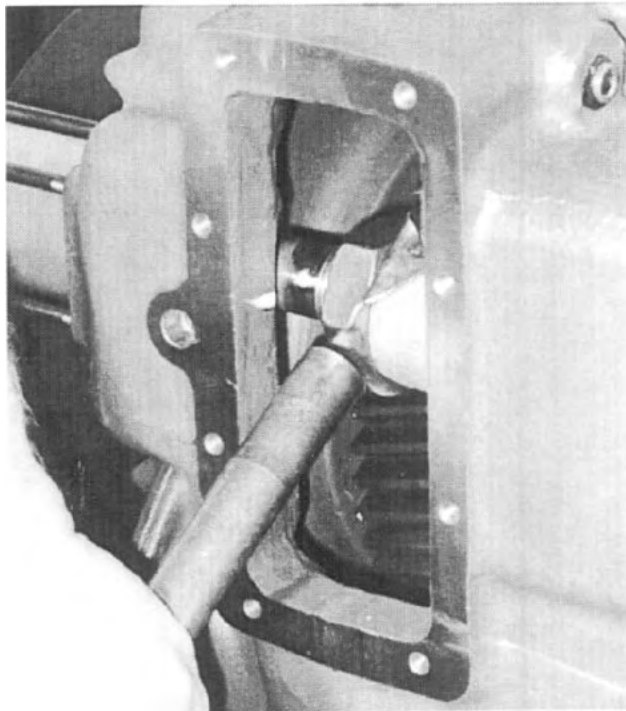

Fig. 102

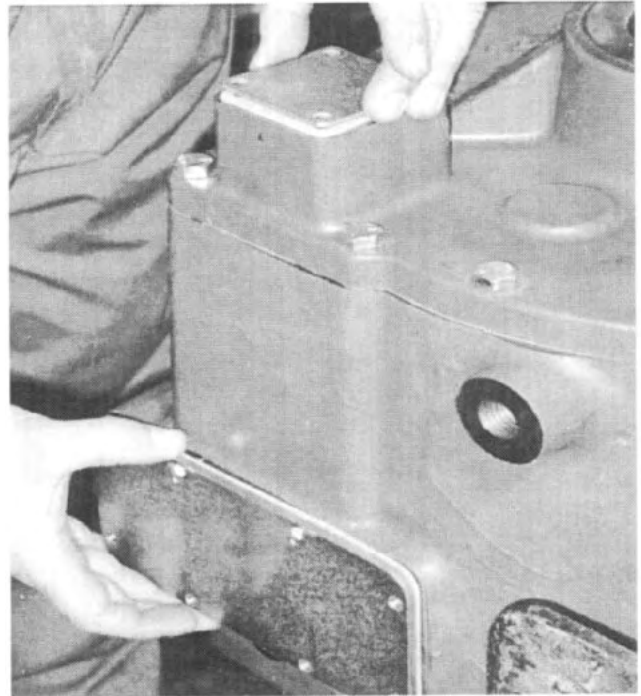

Fig. 104

41. Using a new gasket, secure both the shift shaft access cover plate and shift cylinder bore cap with 1/4-20 bolts. Torque to specification. See Fig. 104.

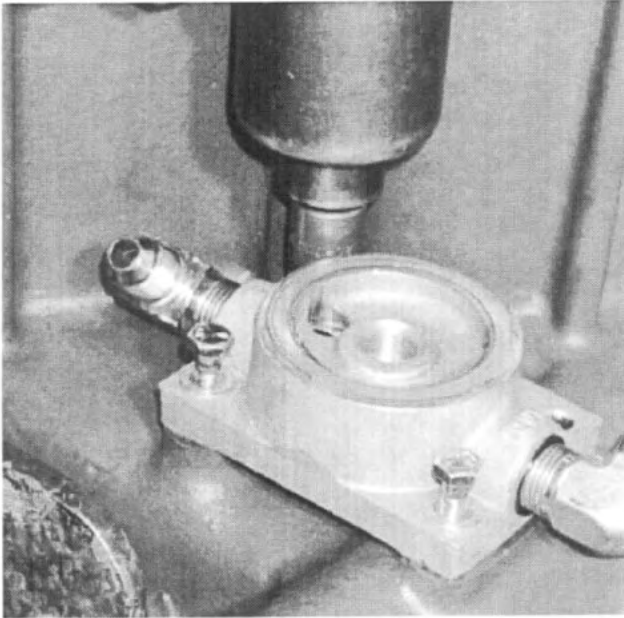

Fig. 105

42. If so equipped and removed during disassembly, attach the oil filter mounting base. Note the inlet and outlet positions as marked. See Fig. 105.

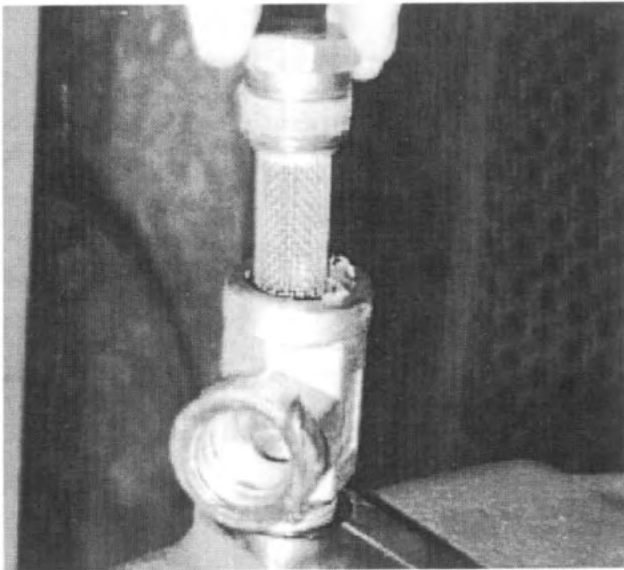

Fig. 106

43. If so equipped, properly route and connect all lubrication lines. Install the oil strainer. See Fig. 106

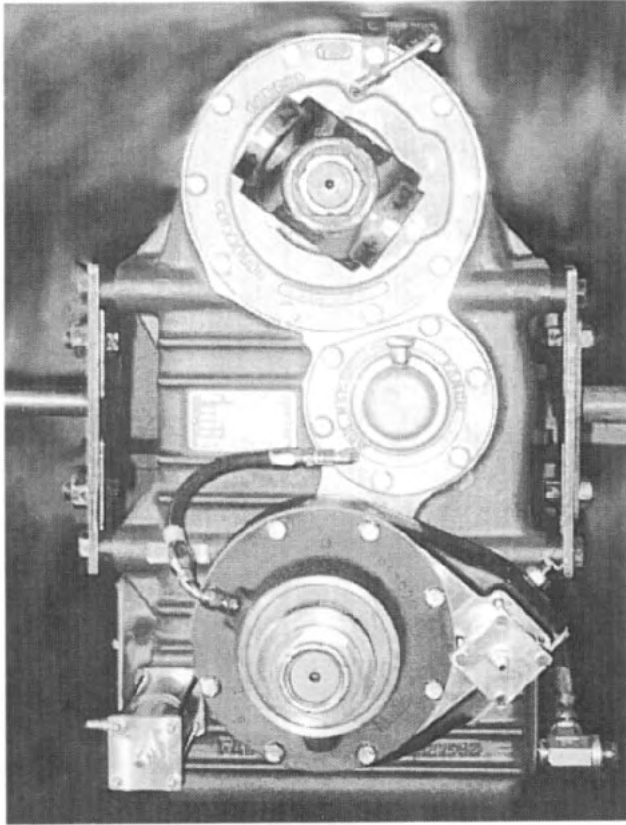

Fig. 107

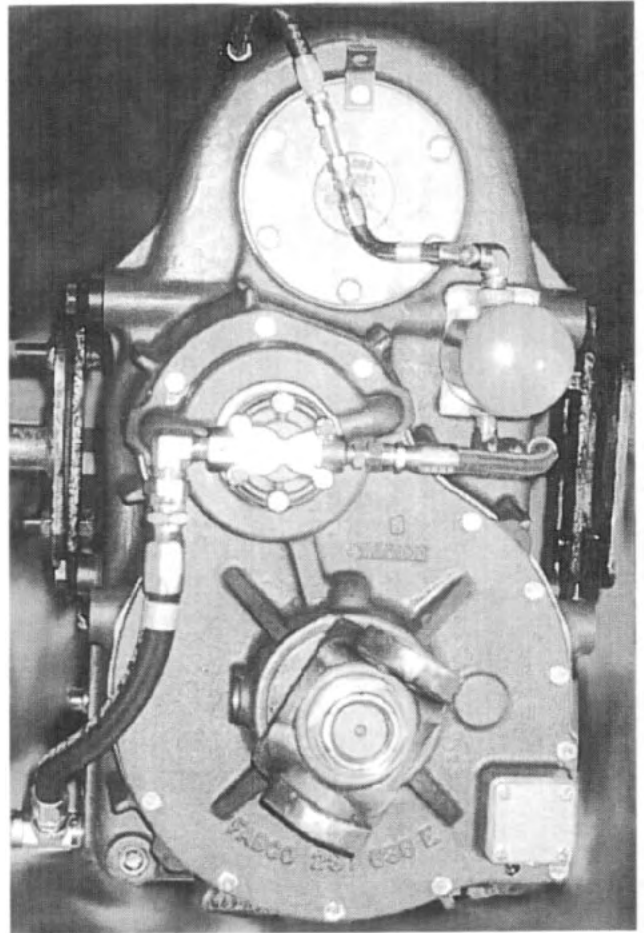

Fig. 108

44. Attach the remaining shaft yokes. The completed transfer case (with pressure lubrication) should appear as above. See Figs. 107-108.

THIS CONCLUDES THE GENERAL ASSEMBLY OF THE TRANSFER CASE

6.7 ASSEMBLY OF THE OIL PUMP

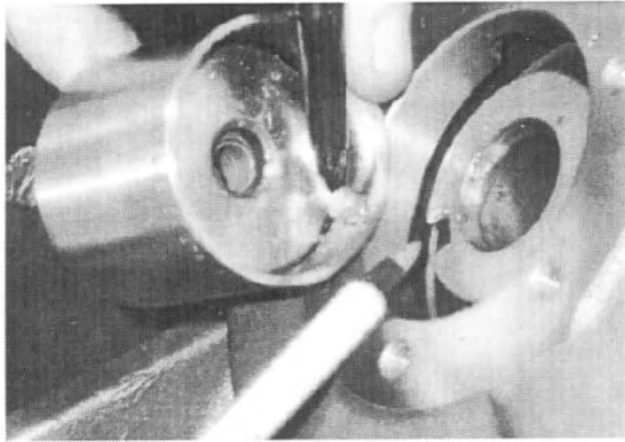

Fig. 109

1. Without the pressure relief spring installed, position the pump cartridge assembly onto the end of the intermediate shaft. See Fig. 109.

⚠ CAUTION: THE CARTRIDGE PIN MUST MATE WITH THE SLOT ON THE INTERMEDIATE SHAFT.



Fig. 110

2. Place the spacer ring assembly, with bushing and gasket, around the pump cartridge and against the sealing face of the rear carrier. Using two (2) 5/16-18 x 1 1/2" long bolts, secure the spacer ring assembly to the rear carrier. See Fig. 110.

⚠ CAUTION: TO AVOID DAMAGE TO THE SEALING SURFACE OF THE SPACER RING ASSEMBLY, TIGHTEN THESE BOLTS FINGER-TIGHT ONLY.



Fig. 111

3. Using a depth micrometer, measure the distance between the outer face of the spacer ring and the pump cartridge assembly. Record this measurement. See Fig. 111.
4. Consult the following chart to determine the proper number of shims to use.

NEGATIVE GAP MEASUREMENT	SHIM QUANTITY
-.079 and Greater	Consult Fabco Engineering
-.048 to -.078	1 Shim
-.017 to -.047	2 Shims
-.001 to -.016	3 Shims

NO GAP MEASUREMENT	SHIM QUANTITY
.000	3 Shims

POSITIVE GAP MEASUREMENT	SHIM QUANTITY
.001 to .016	3 Shims
.017 to .047	4 Shims
.048 to .078	5 Shims
.079 to .109	6 Shims
.110 to .140	7 Shims
.141 and Greater	Consult Fabco Engineering

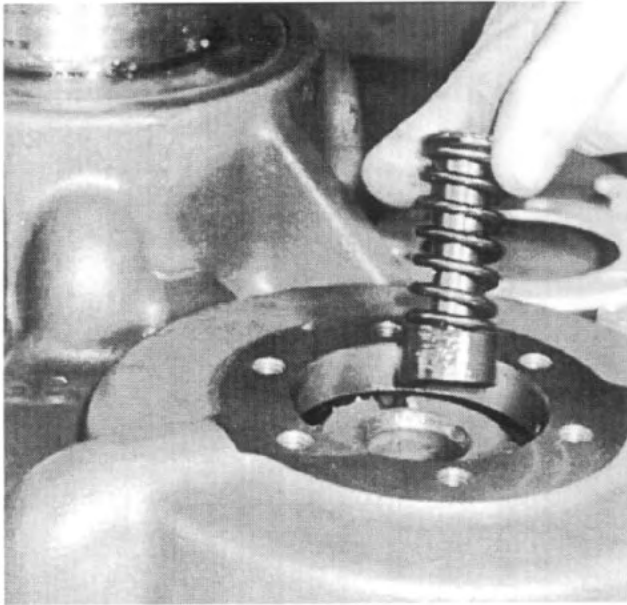

Fig. 112

5. After shim measurements are taken and noted, remove the spacer ring and pump cartridge assembly from the end of the intermediate shaft. Install the pressure relief spring into the cavity at the end of the intermediate shaft. See Fig. 112.

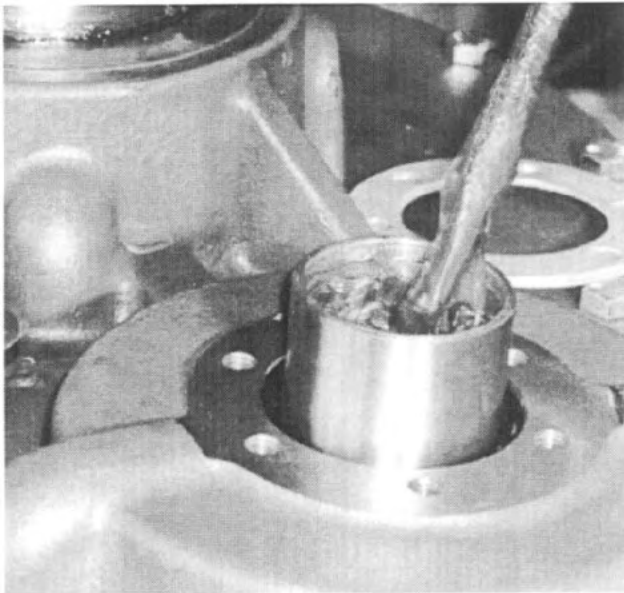

Fig. 113

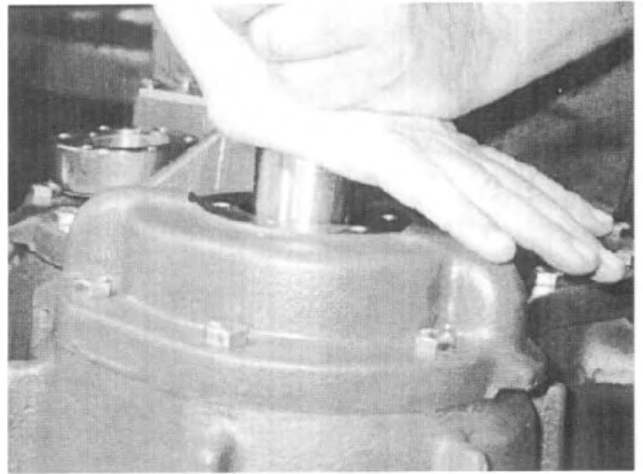

Fig. 114

6. Liberally grease all of the components of the pump cartridge assembly and reinstall. Seat the pressure relief spring by pushing down on it several times. See Figs. 113-114.

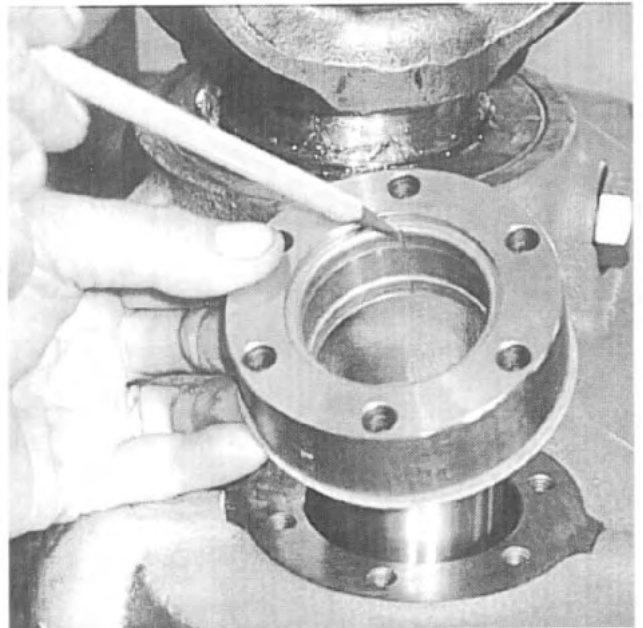

Fig. 115

7. Reinstall the spacer ring assembly, with the bushing and gasket, onto the end of the intermediate shaft. See Fig. 115.

CAUTION: THE CARTRIDGE PIN MUST MATE WITH THE SLOT ON THE INTERMEDIATE SHAFT. SEE FIG. 109.

NOTE: THE OIL GROOVE OF THE SPACER RING ASSEMBLY BRONZE BUSHING MUST BE IN THE 6 O'CLOCK POSITION. THIS POSITION FACES THE BOTTOM OF THE TRANSFER CASE.

8. Place the number of shims, determined from steps 3-4, on top of the spacer ring.

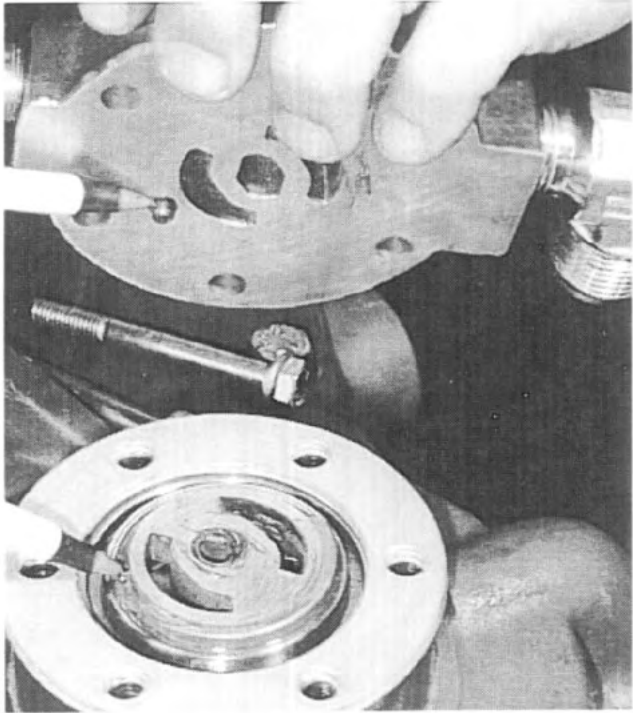

Fig. 116

9. Install the oil pump cap onto the spacer ring and pump cartridge assembly. *See Fig. 116.*

⚠ CAUTION: THE PIN IN THE OIL PUMP CAP MUST BE POSITIONED SUCH THAT IT CONTACTS THE CUTOUT GROOVE OF THE PUMP CARTRIDGE ASSEMBLY. FAILURE TO DO SO WILL CAUSE THE PUMP NOT TO OPERATE.

10. Apply Permatex # 2 or the equivalent to the mounting bolts and evenly torque according to specifications.

THIS CONCLUDES THE ASSEMBLY OF THE OIL PUMP

NOT SHOWN
OIL LEVEL & DRAIN PLUG: 50 LB.-FT.
TEMPERATURE SENSOR: 25 LB.-FT.
OIL FILTER BRACKET: 15 LB.-FT.

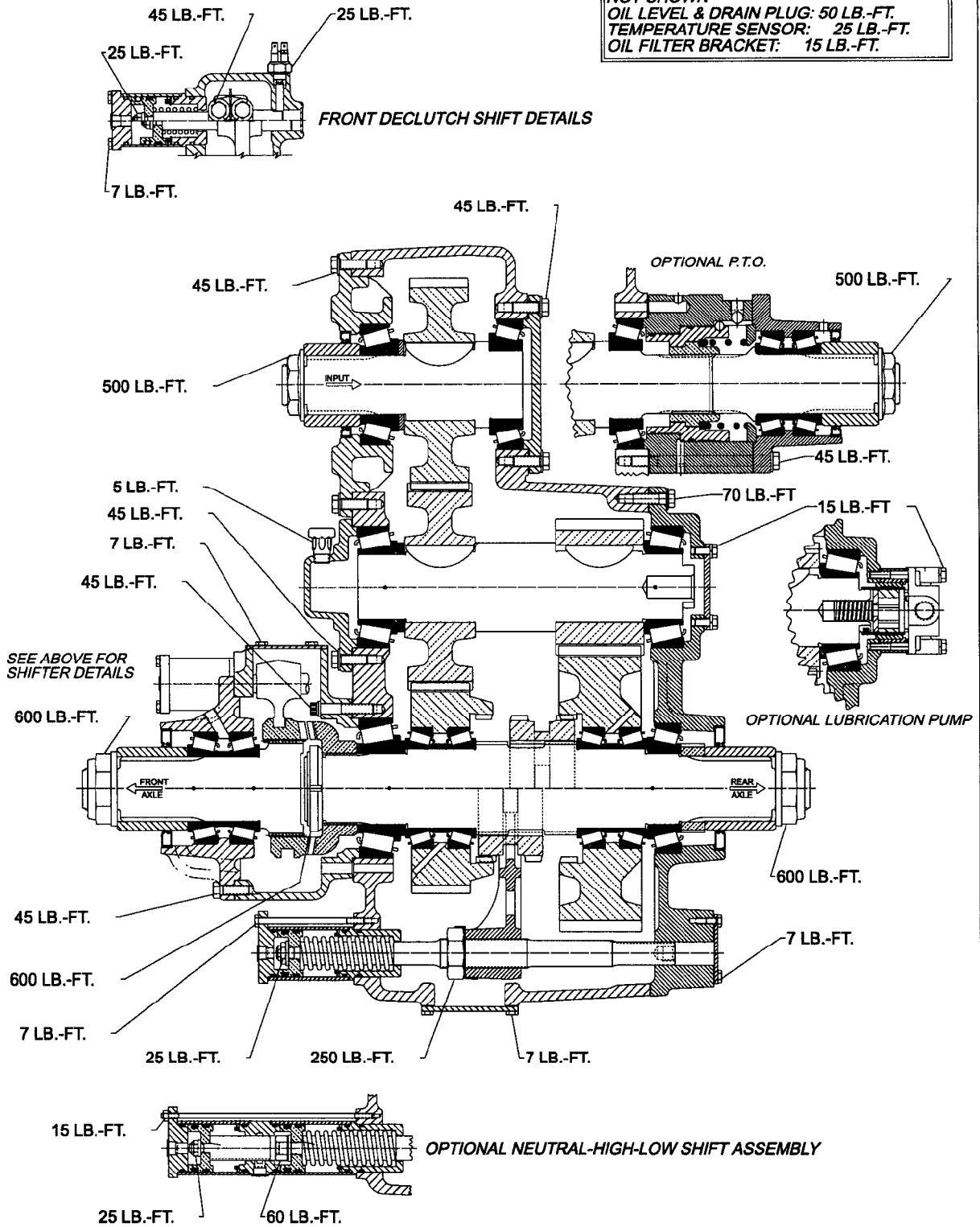

**ALL TORQUE VALUES ARE FOR DRY UNLUBRICATED THREADS,
 AND SHOULD BE WITHIN 10% OF THE VALUES SHOWN.**

9.0 TOOLS

Details of tooling to facilitate the servicing of the Fabco TC-270 Transfer Case.

Service tools may be manufactured to these drawings or Fabco Automotive may be contacted for price and availability.

The manufacture of these tools should be carried out by professional machinists and certified welders, following typical and good workmanship procedures and safe practices.

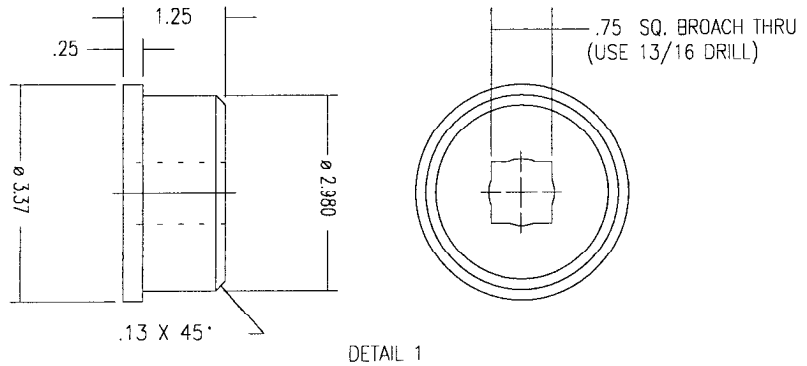

DETAIL 1

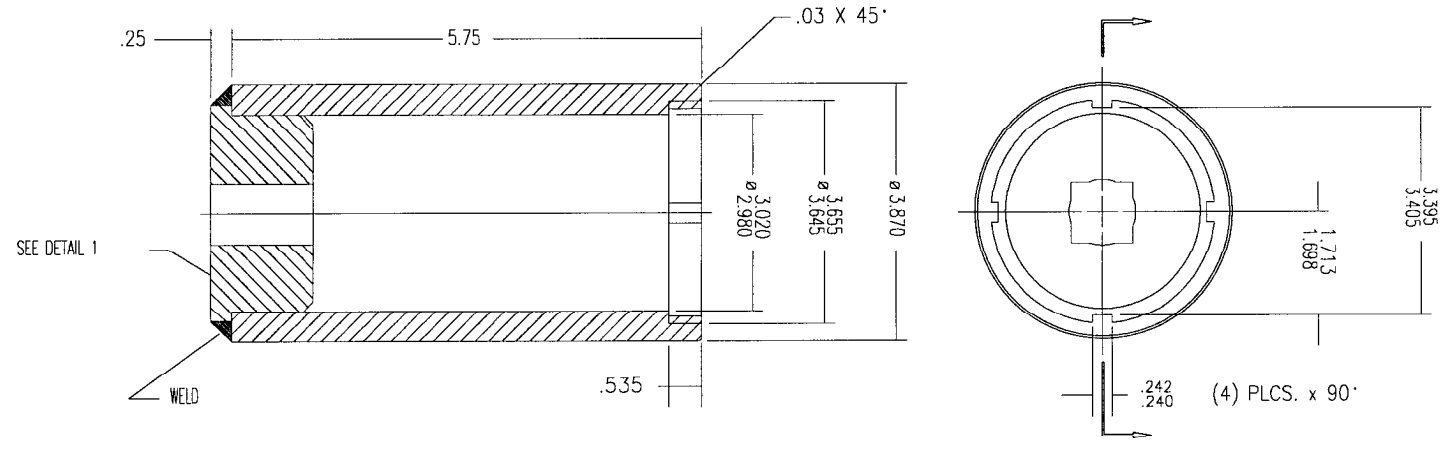

SEE DETAIL 1

MATERIAL: 4140
HEAT TREAT TO Rc 40-45

866-0687-006 BEARING LOCKNUT WRENCH, REAR OUTPUT SHAFT

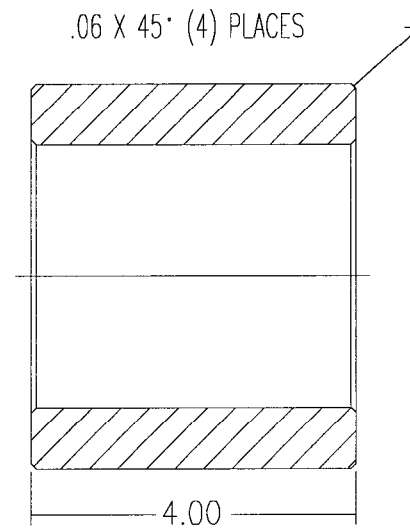
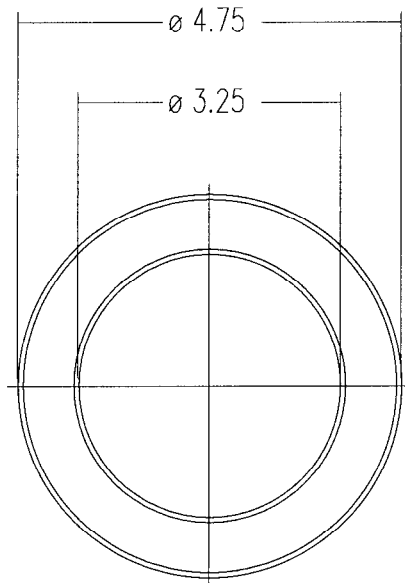

MATERIAL: MILD STEEL

866-0749 SETUP SLEEVE, REAR OUTPUT SHAFT DIRECT DRIVE

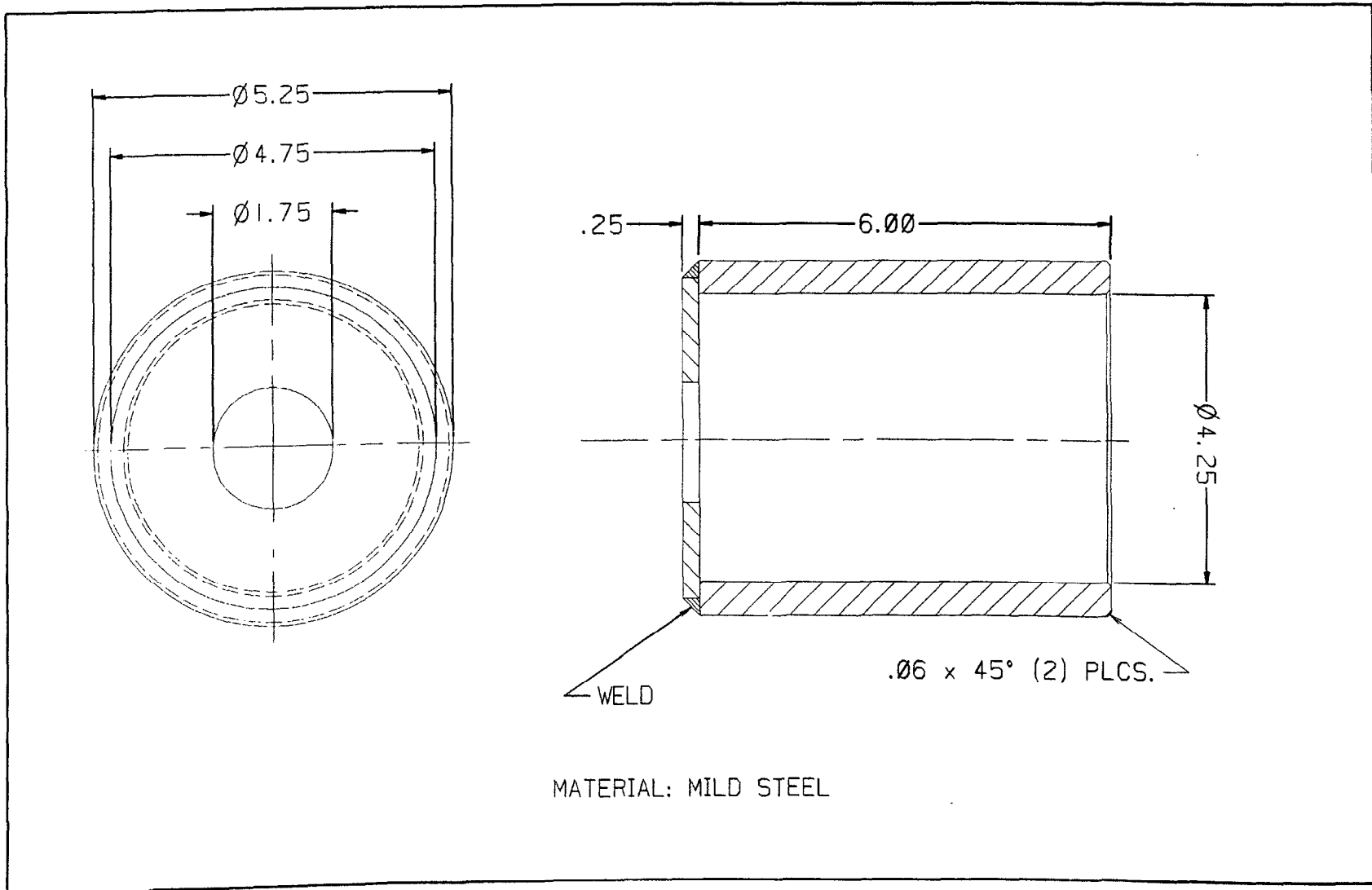

866-0750 SETUP SLEEVE. REAR OUTPUT SHAFT UNDERDRIVE

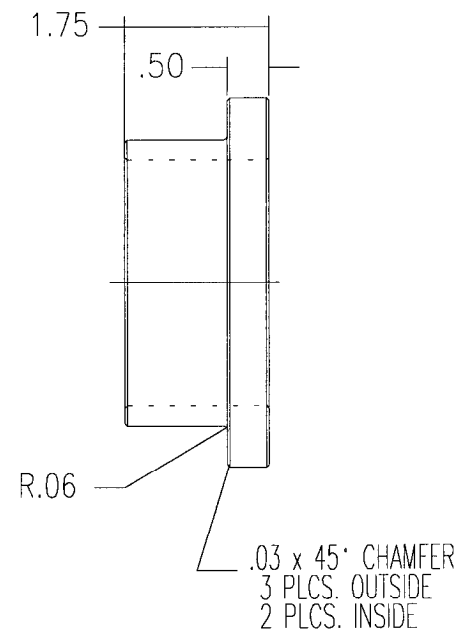
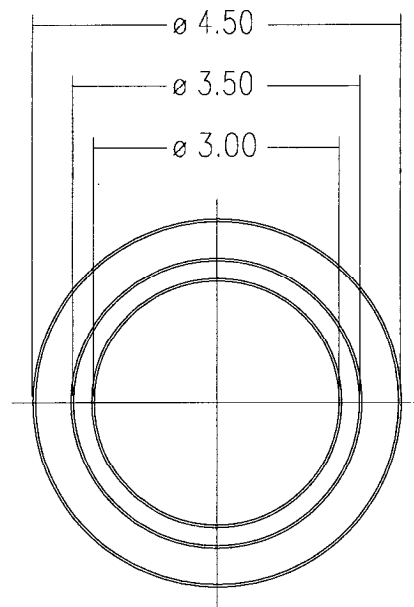

MATERIAL: MILD STEEL

866-0751 SETUP SLEEVE, REAR OUTPUT SHAFT

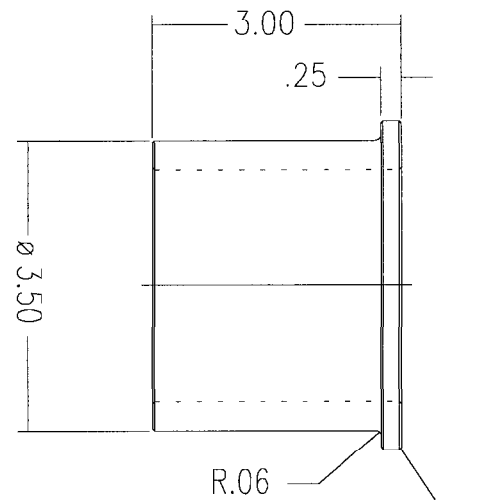
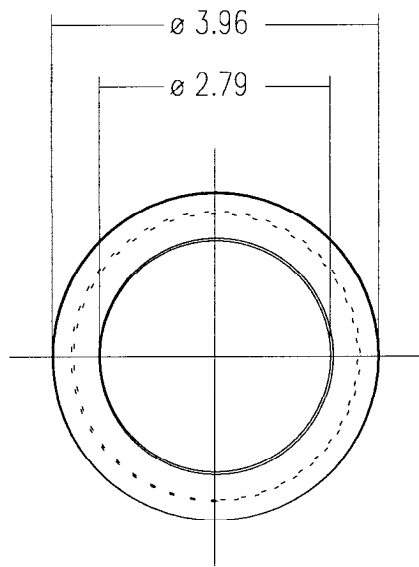

.03 x 45° CHAMFER
3 PLCS. OUTSIDE
2 PLCS. INSIDE

MATERIAL: MILD STEEL

866-0752 SETUP SLEEVE, FRONT OUTPUT SHAFT